

# **XITECH** **Instruments, Inc.**

## **Installation & Operation Manual**

### **Total Fluids (Dual Pump) Recovery with Groundwater Pumping, Skimming & Vacuum**

### **Using Xitech's AI400 Groundwater Pump, 2" Skimmer, 5015ES Skimmer Controller and 5016 Groundwater Pump Controller**

**Caution:**  
**Read rules for safe operation and instructions  
carefully.**

© Copyright 2010 REV 1/2011

**06 Camino De Los Desmontes, Placitas, New Mexico 87043**

**Phone: 505-867-0008 Fax: 505-867-0212**

**Web site: [www.xitechinc.com](http://www.xitechinc.com)**

**E-mail: [xitechinc@xitechinc.com](mailto:xitechinc@xitechinc.com)**

## **3 YEAR WARRANTY**

This product is warranted to the original purchaser to be free from defective materials and workmanship. Under this warranty the product will be repaired or replaced at our option, without charge for parts or labor.

This warranty does not apply to the air logic valve and hydrophobic filter.

The period of this warranty covers 3 years on parts and labor from date of original purchase.

This warranty entitles the original purchaser to have the warranted parts and labor rendered at no cost for the period of the warranty described above when the instrument is carried or shipped, prepaid, to our factory, together with proof of purchase.

## **RULES FOR SAFE OPERATION**

1. Please review carefully and abide by the maximum limits placed on each type of equipment.
2. Please follow standard electrical practices and safety precautions when installing AC power to our products.

# Total Fluids (Dual Pump) Recovery

## Groundwater Pumping, Skimming & Vacuum

The Xitech Total Fluids Recovery system (Figure 1) requires a six inch diameter well or greater. This system includes: an intrinsically safe Auto-Isolator 400 pneumatic Groundwater Pump (Figure 8) which removes groundwater down to 200 feet deep, 2" Xitech Skimmer (Figure 9), a programmable skimmer Controller Model 5015ES (Figures 1 and 7) with individual skimmer shutoffs (8 skimmers) and a high product tank shutoff, a programmable groundwater pump Controller Model 5016 (Figure 1 and 6) with individual groundwater pump controls (8 pumps) and a SCADA shutoff communications port. Both controllers provide central control of the pumps and skimmers, collect individual run times, and have individual automatic and manual controls. The 5016 Controller can be controlled by a SCADA computer. The 5015ES Controller provides intermittent control of the skimmers.

## System Installation

STEP 1. Mount the 5016 Pump Controller (Figure 5) in a vertical position near the air source, power source, and other above ground controls if possible. **CAUTION:** The 5016 Controller is NOT intrinsically safe. Do not use in a CLASS I hazardous area.

STEP 2. Mount the 5015ES Skimmer Controller (Figure 5) in a vertical position near the air source, power source, and other above ground controls if possible. **CAUTION:** The 5015ES Skimmer Controller is NOT intrinsically safe. Do not use in a CLASS I hazardous area.

STEP 3. If a SCADA computer is present on the site and you wish to have the SCADA be able to shut down all the groundwater pumps, attach a two conductor communication cable from the 5016 Controller junction box (Figures 1 and 6) over to the existing SCADA computer. This communication cable will allow the SCADA computer to automatically turn off all groundwater pumps and skimmers when necessary. **NOTE:** the SCADA needs to provide our 5016 Controller with a normally CLOSED dry contact switch signal.

STEP 4. Attach a AC 120 volt power source to both controllers (Figures 6 and 7). Turn on the controller power switch of both controllers. If the red "Tank Full" light comes on, you have a problem with the SCADA signal wiring or the product tank high level shutoff cable. Turn off the power switches and recheck wiring. If the "Tank Full" light continues to stay on call the factory.

# **Total Fluids (Dual Pump) Recovery**

## **Groundwater Pumping, Skimming & Vacuum**

STEP 5. Install a 1/2" OD air supply tubing from the main air source to the INLET of the 5016 and 5015ES Controllers. Do NOT apply air pressure YET. NOTE: The air supply needs to be free of WATER and OIL to minimize pump maintenance.

STEP 6. Install a pressure regulator (Figures 3 and 4) in each well vault. Attach a 1/2" OD air supply tubing to one of the outlets of the 5016 Controller. Run this 1/2" tubing through the 3" vacuum cap port labeled "A" (Figures 3 and 4), through the 3" horizontal vacuum line running out to the well vault, through the 3" vacuum cap port labeled "A", and over to the inlet of the groundwater pump pressure regulator. CAUTION: Please be sure not to have any sharp 90 degree elbows in the 3" vacuum line from the compound to the well vaults. Use swept elbows or two 45 degree elbows, do not use 90 degree elbows.

STEP 7. Attach a 3/8" OD air supply tubing to one of the outlets of the 5015ES Controller. Run this 3/8" tubing through the 3" vacuum cap port labeled "G" (Figures 3 and 4), through the 3" horizontal vacuum line running out to the well vault, through the 3" vacuum cap port labeled "G", and over to the inlet of the 1/4" - 3/8" filter union.

STEP 8. Attach a 1/2" OD product tubing to the compound product holding tank manifold (Figure 1). Run this 1/2" product tubing through the 3" vacuum cap port labeled "P" (Figures 1, 3 and 4), through the 3" horizontal vacuum line running out to the well vault, through the 3" vacuum cap port labeled "P", and over to the inlet of the 5/16" - 1/2" product union.

STEP 9. Install the 4-conductor switching cable (Figure 1) from the 5015 and 5016 Controller junction boxes, through the 3" vacuum cap port labeled "L" (Figures 3 and 4), through the 3" horizontal vacuum line running out to the well vault.

STEP 10. Install a separate ridged common horizontal groundwater discharge pipe of 3/4" ID or greater from the compound water treatment tank out to all of the well vaults. Attach a male 3/4" NPT pipe thread onto the end of this line inside each well vault. Attach a Xitech 3/4" NPT 2-way shutoff valve or a Xitech 3/4" NPT flowtotalizer and shutoff valve assembly (Figures 3 and 4) onto the horizontal discharge piping in the well vault.

STEP 11. Place a Xitech Groundwater Pump and Xitech 6" Well Seal (Figure 8) on the ground near the well.

NOTE: We suggest the inlet of the Xitech Auto-Isolator 400 Pump should be placed near the bottom of the well.

# **Total Fluids (Dual Pump) Recovery**

## **Groundwater Pumping, Skimming & Vacuum**

STEP 12. Cut a length of 3/4" ID discharge hose to cover the distance from the top of the well down to the top of the pump. Attach this discharge hose to the barb fitting on the bottom side of the 6" well seal labeled "D" (Figure 8). Secure this end of the hose with a stainless steel hose clamp. Attach the other end of the discharge hose to the barb fitting on the top of the groundwater pump labeled "D". Secure this end of the hose with a stainless steel hose clamp.

STEP 13. Cut a length of 3/4" discharge hose to cover the distance from the top of the well seal over to the inlet of the flowtotalizer or 2-way shutoff valve (Figures 2 and 3). Attach one end of the discharge hose to the inlet of the flowtotalizer or 2-way shutoff valve. Secure this end of the hose with a stainless steel hose clamp. Attach other end of the discharge hose to 3/4" elbow barb fitting on the top of the well seal labeled "D".

STEP 14. Cut a length of 1/2" OD air supply tubing to cover the distance from the top of the well down to the top of the groundwater pump plus 5 feet. CAUTION: Please keep dirt from getting into this line! Slide the tubing through the top of the 6" well seal fitting labeled "A" until 5 feet of tubing is sticking out of the top of the well seal. Attach the long end of the 1/2" OD tubing to the top of the groundwater pump barb fitting labeled "A" (Figure 8). Secure this tubing to the barb fitting with a stainless steel hose clamp. Attach the other end of the air supply tubing to the outlet of the pressure regulator.

STEP 15. Cut another length of 1/2" OD air exhaust tubing same length as the air supply line. Slide the tubing through the top of the 6" well seal fitting labeled "E" (Figure 8) until 5 feet of tubing is sticking out of the top of the well seal. Attach the long end of the tubing to the top of the groundwater pump barb fitting labeled "E" (Figure 8). Secure tubing to the barb fitting with a stainless steel hose clamp. Attach a 1/2" check valve to the other end of the air exhaust tubing sticking out of the top of the 6" well seal.

STEP 16. Cut a length of safety cable the same length as the 1/2" air supply tubing. Secure the safety cable to the underside well seal eyebolt and to the eyebolt on the top of the groundwater pump using two stainless steel clamps at each end.

NOW, place the groundwater pump into the well.

# **Total Fluids (Dual Pump) Recovery**

## **Groundwater Pumping, Skimming & Vacuum**

STEP 17. Place Xitech 2” Skimmer and Xitech 6” Insert Well Seal (Figure 9) on the ground near the well. NOTE: We suggest you locate the middle of the skimmer’s well screen at your desired water depression depth.

STEP 18. Cut a length of 5/16”OD product discharge tubing to cover the distance from the top of the well down to the top of the skimmer plus 5 feet. Feed one end of this tubing through the bottom side of the 6” Insert Well Seal labeled “P” until there is 5 feet coming out of the top side of the well seal. Attach the long end of this tubing to the top of the skimmer labeled “P”. Attach the other end coming out of the top side of the well seal to the outlet of the 5/16” - 1/2” quick-connect union.

STEP 19. Cut a length of 1/4” OD air supply tubing to cover the distance from the top of the well down to the top of the skimmer, plus 5 feet. CAUTION: Please keep dirt from getting into this line! Slide the tubing through the bottom side of the 6” Insert Well Seal fitting labeled “G” until 5 feet of tubing is sticking out of the top side of the well seal. Attach the long end of the tubing to the top of the skimmer fitting labeled “G” (Figure 9). Attach the other end of the air supply tubing to the outlet of the 1/4” - 3/8” quickpush filter union.

STEP 20. Cut another length of 1/4” OD air exhaust tubing same length as the air supply tubing. Slide this tubing through the bottom side of the well seal fitting labeled “E” (Figure 9) until 5 feet of tubing is sticking out of the top side of the well seal. Attach the long end of the tubing to the top of the skimmer labeled “E” (Figure 9). Attach a quick exhaust check valve to the other end sticking out of the top side of the well seal.

STEP 21. Cut a length of safety rope the same length as the air supply tubing. Secure the safety rope to the underside well seal eyebolt and to the eyebolt on the top of the skimmer.

STEP 22. Attach the water level switch assembly (Figures 3 and 4) to the center of the skimmer’s slotted well screen using tie wraps. Slide the level switch cable through the bottom side of the 6” Insert Well Seal fitting labeled “L” (Figure 9) until 5 feet of the level switch cable is sticking out of the top side of the well seal. Slide the end of the level switch cable coming out of the top of the well seal through the 3” conduit cap fitting labeled “L” until 1 foot of the cable is sticking through the 3” vacuum cap. Attach the wires from the level switch cable to the 4-conductor switching cable in the horizontal 3” vacuum line.

# **Total Fluids (Dual Pump) Recovery Groundwater Pumping, Skimming & Vacuum**

NOW, place the skimmer into the well. Repeat STEPS 11 - 22 for all of the wells.

Installation of the system is now ready to operate.

## **System Operation**

Operating air supply pressure limits:

Minimum operating pressure is 70 psi.

Maximum operating pressure is 150 psi.

STEP 1. To obtain your desired level of water depression, first, make sure the air pressure regulator at the well is off (will not pass air). Second, apply 140 psi air pressure to the inlet of the 5016 Controller. Third, turn on the power to the controller. Next, go to the manual control window, select the station number for this well, and turn ON this station.

NOTE: If there is NO SCADA signal wiring attached to the 5016 Controller at this time. Then, go to the level sensor on window in the 5016 Controller and turn off the level sensor.

STEP 2. Go to the well and slowly begin increasing the air pressure until the pumping rate lowers the water level to the desired depression depth.

STEP 3. Return to the 5016 Controller. Leave the manual control window (this will turn off the groundwater pump) and go to the program window. Input "01" minutes for the station # that is controlling this well. Go to the "Status" window. Your station should say "RUNNING". Go to the well and confirm that the groundwater pump is now running. Also, confirm the water depression level is being maintained. NOTE: Increasing the time increases the depression window. Decreasing the air supply pressure decreases the depression window. Leave the groundwater pump running.

NOTE: You must now wait until there is a sizable product thickness in the well before continuing.

# **Total Fluids (Dual Pump) Recovery**

## **Groundwater Pumping, Skimming & Vacuum**

STEP 4. Go to the 5015ES Skimmer Controller. Apply 90 psi air pressure to the inlet of the 5015ES Skimmer Controller. Turn on the power to the 5015ES Controller. If there is NO SCADA signal wiring attached to the 5015ES Controller at this time. Then, go to the level sensor on window in the 5015ES Controller and turn off the level sensor.

STEP 5. Go to the manual control window, select the station number that controls the skimmer in this well, and turn ON this station.

STEP 6. Go to the well and observe how long the skimmer takes to remove 1/2 of the starting product thickness in the well.

STEP 7. Go to the 5015ES Controller and turn off this station. The skimmer should stop pumping. Observe how long it takes for the product thickness to return to its original thickness.

STEP 8. Go to the 5015ES first programming window (Date, Time and Duration window). Input tomorrow's date, the desired start time for this well, and the pumping duration (i.e. the amount of time it took in minutes to remove 1/2 of the product thickness from the well) for this well.

STEP 9. Go to the 5015ES second programming window (Cycles Window). Input the cycles per day based on the amount of time it took for the product thickness to recover.

Repeat this set up for all of the other wells.

# **Total Fluids (Dual Pump) Recovery**

## **Groundwater Pumping, Skimming & Vacuum**

### **Explanation of the 5016 Groundwater Pump Controller Software Windows**

**WINDOW #1:** This is the first window of four windows. Here you can observe the status of each of the 8 outlet stations and the elapsed run of each outlet station. You can also reset the elapsed run time for any station in this window. There are five different statuses that can show in this window: Inactive, Pump Off, Pump On, System Off, Low Battery.

Inactive: There is no program for this station.

Pump Off: There is a program and the controller is waiting for a level switch signal to turn on the pump.

Pump On: The pump should be running.

System Off: The controller has received a shut down signal from the SCADA computer. All stations should be off.

Low Battery: The backup batteries in the PLC computer preserves the program data. When AC power is lost and the batteries are low and need replacing.

**WINDOW #2:** This window is where you program the pumping duration time: the longer the time, the deeper the water depression.

**WINDOW #3:** This window also has a setting for turning off the outside SCADA input signal. CAUTION: When the Level Sensor is OFF, the 5016 Controller will NOT look for an outside SCADA control signal.

**WINDOW #4:** This window is used to temporarily override any of the 8 stations' present states. OFF means this station is not running. ON means this station is running. Any changes you make in this window will go away when you leave this window.

# **Total Fluids (Dual Pump) Recovery**

## **Groundwater Pumping, Skimming & Vacuum**

### **Explanation of the 5015ES Skimmer Controller Software Windows**

**SET UP MODE:** This is where you set the actual time and date for the computer.

**DIRECT MODE:** This is where you program each of the 8 outlet stations.

**STATUS WINDOW:** This is the first window in the Direct Mode. Here you can observe the state of each of the 8 outlet stations and the elapsed run of each outlet station. This window is also where you can reset the elapsed time of any station.

**PROGRAM WINDOW #1:** This is the second window in the Direct Mode. This is where you program each station's START DATE, START TIME, and DURATION or pump run time.

**PROGRAM WINDOW #2:** This is the third window in the Direct Mode. This is where you program each station's CYCLES per day, PERIODS or days delay between run times, and LEVEL SENSOR test mode. **CAUTION:** When the Level Sensor is OFF the 5000ES will NOT look for a High Product Tank signal.

**MANUAL CONTROL WINDOW:** This is the fourth window in the Direct Mode. This window is used to temporarily override any of the 8 stations present states. The "P" means that the manual control will be overridden by the program. The "M" means manual control only. OFF means that this station is not running. ON means this station will stay running until you leave this window.

# **Total Fluids (Dual Pump) Recovery**

## **Groundwater Pumping, Skimming & Vacuum**

### **5015ES Skimmer Controller**

### **Computer Data Windows For The**

### **SET UP & DIRECT Modes**

#### **SET UP MODE:**

##### **System Time and Date**

1. Mode Selection Window  
CONTROL MODE  
**SETUP**
2. Set Current Time Window  
SET TIME: **HH:MM:SS**  
USE 24 HOUR TIME
3. Set Current Date Window  
SET DATE: **MM-DD-YY**

#### **DIRECT MODE:**

##### **Stations Set Up, Level Sensor, and Manual Control**

1. Mode Selection Window  
CONTROL MODE  
**DIRECT**
2. Station Status Window  
STATION 1 INACTIVE  
TOTAL TIME = **00000:00**
3. Station Set Up Window  
**1 START MM-DD-YY HH:MM**  
**DURATION HH:MM**
4. Station Cycles & Level Sensor Window  
**1 CYCLES 00 (00-99)**  
**LEVEL SENSOR ON**
5. Station Manual Control Window  
**1 STATION P OFF**

# **Total Fluids (Dual Pump) Recovery**

## **Groundwater Pumping, Skimming & Vacuum**

### **Key Pad Descriptions**

**MENU:** This Key changes windows.

The left and right arrow Keys move the cursor to the next programmable field.

The up arrow Key increases the value in the field the cursor is on.

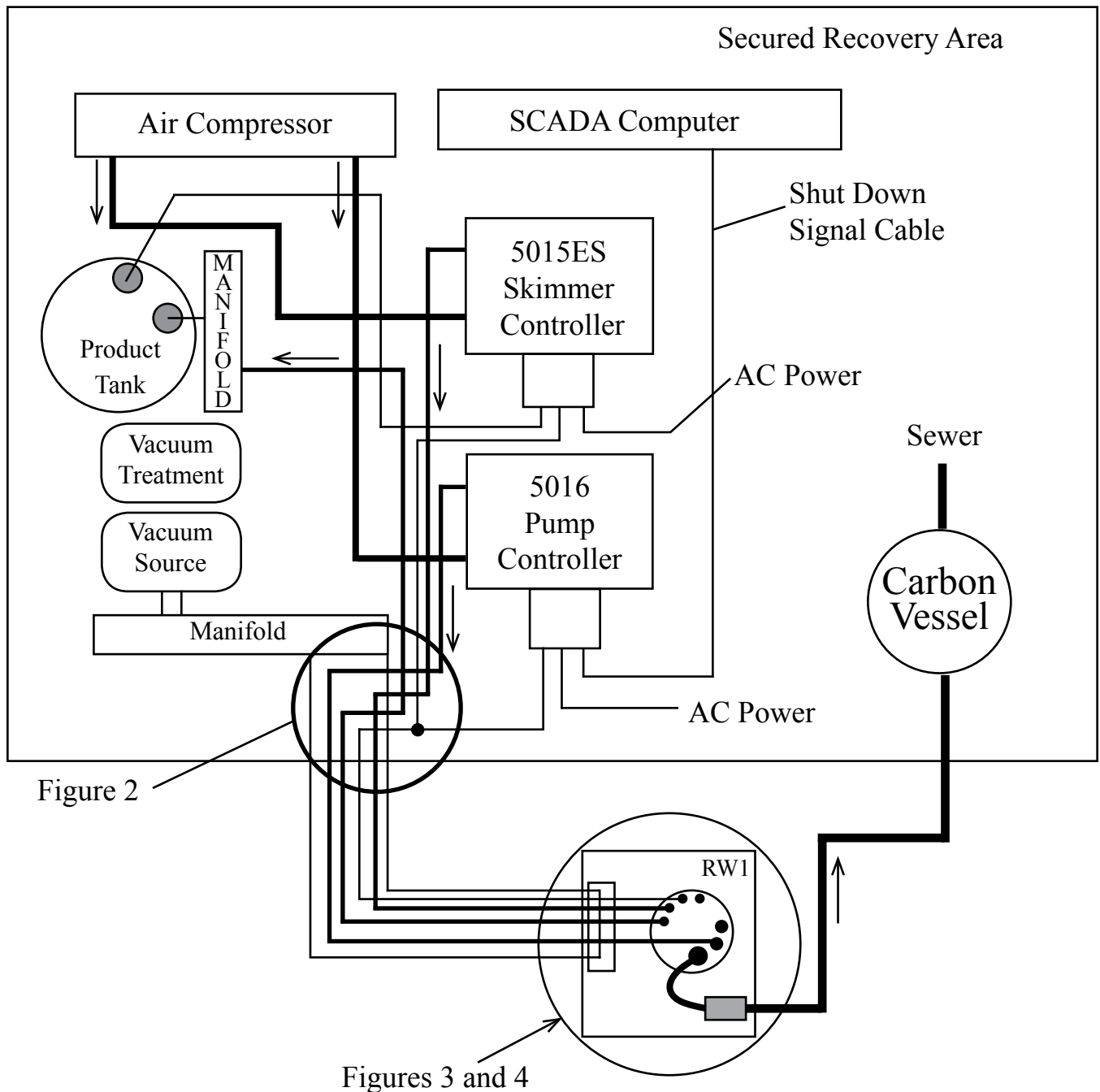
The down arrow Key decreases the value in the field the cursor is on.

**TIME RESET:** This Key will reset the elapsed run time of a station when you are in the STATUS WINDOW.

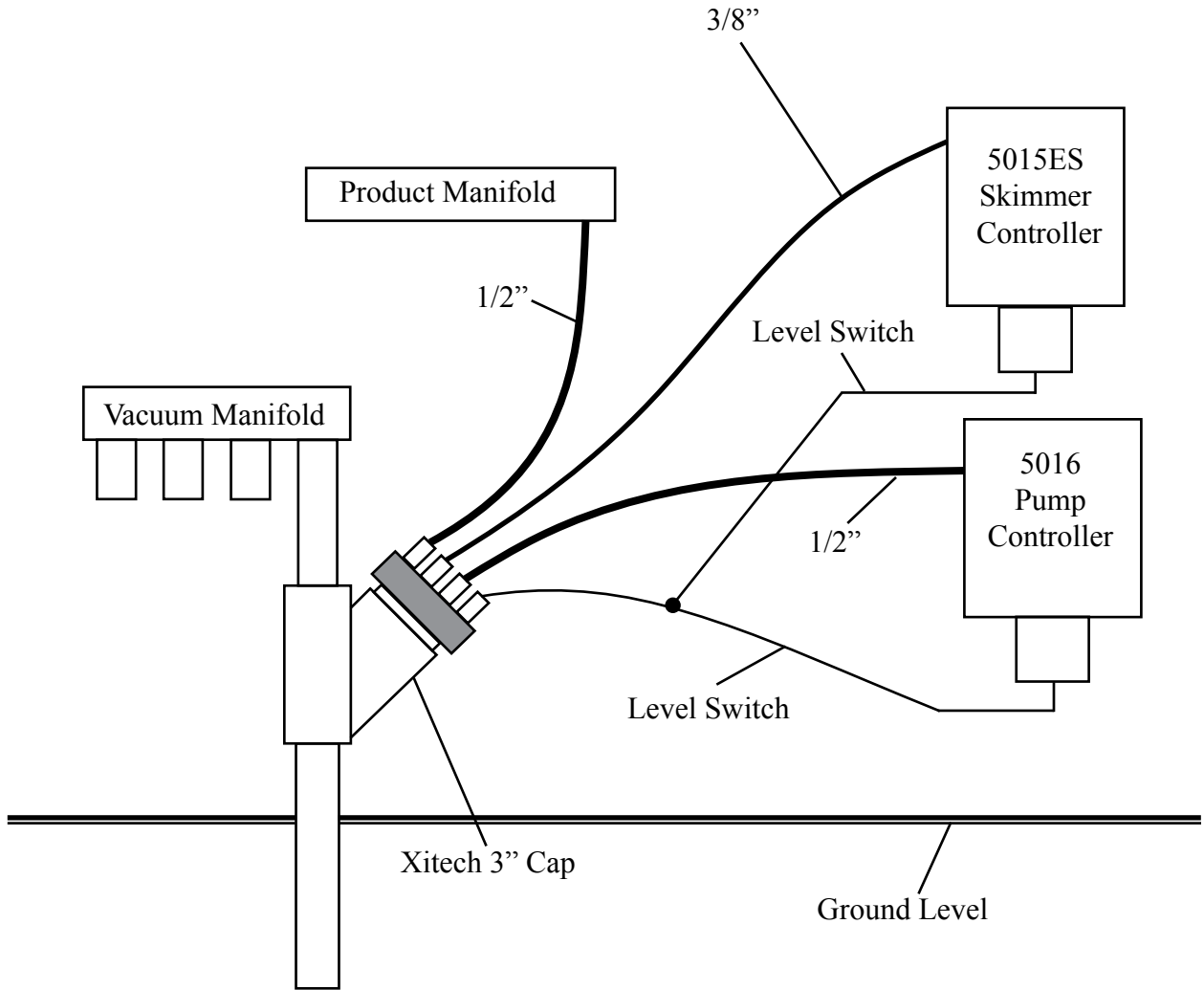
**REV:** This Key is to show you what software version is currently being used by your computer.

**DEL:** This Key will replace all programmed values with preset default values. This Key will NOT delete the elapsed run times.

# Total Fluids (Dual Pump) Recovery Groundwater Pump and Skimmer and Vacuum Individual Air Supply and Common Discharge Return

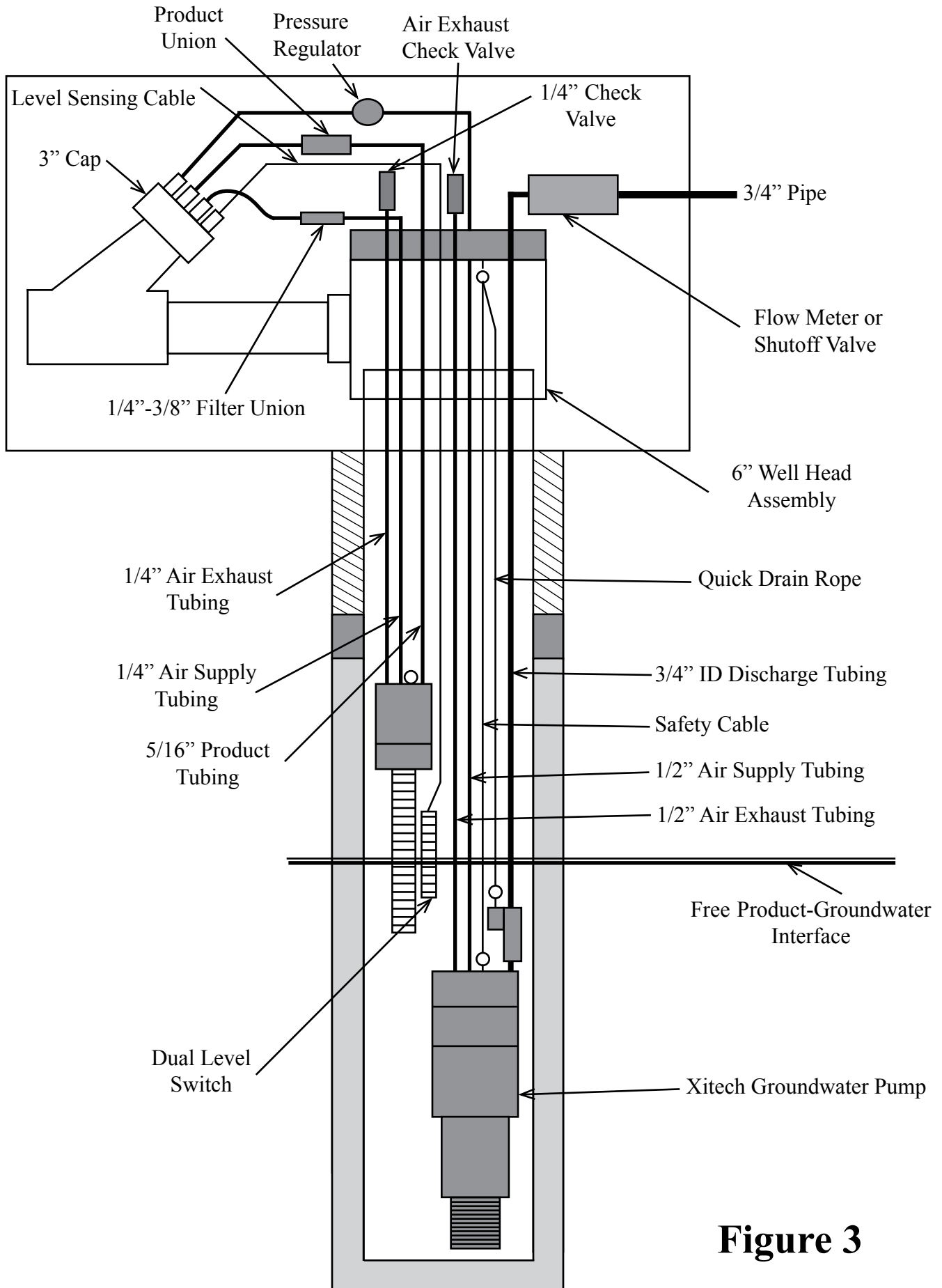


**Figure 1**



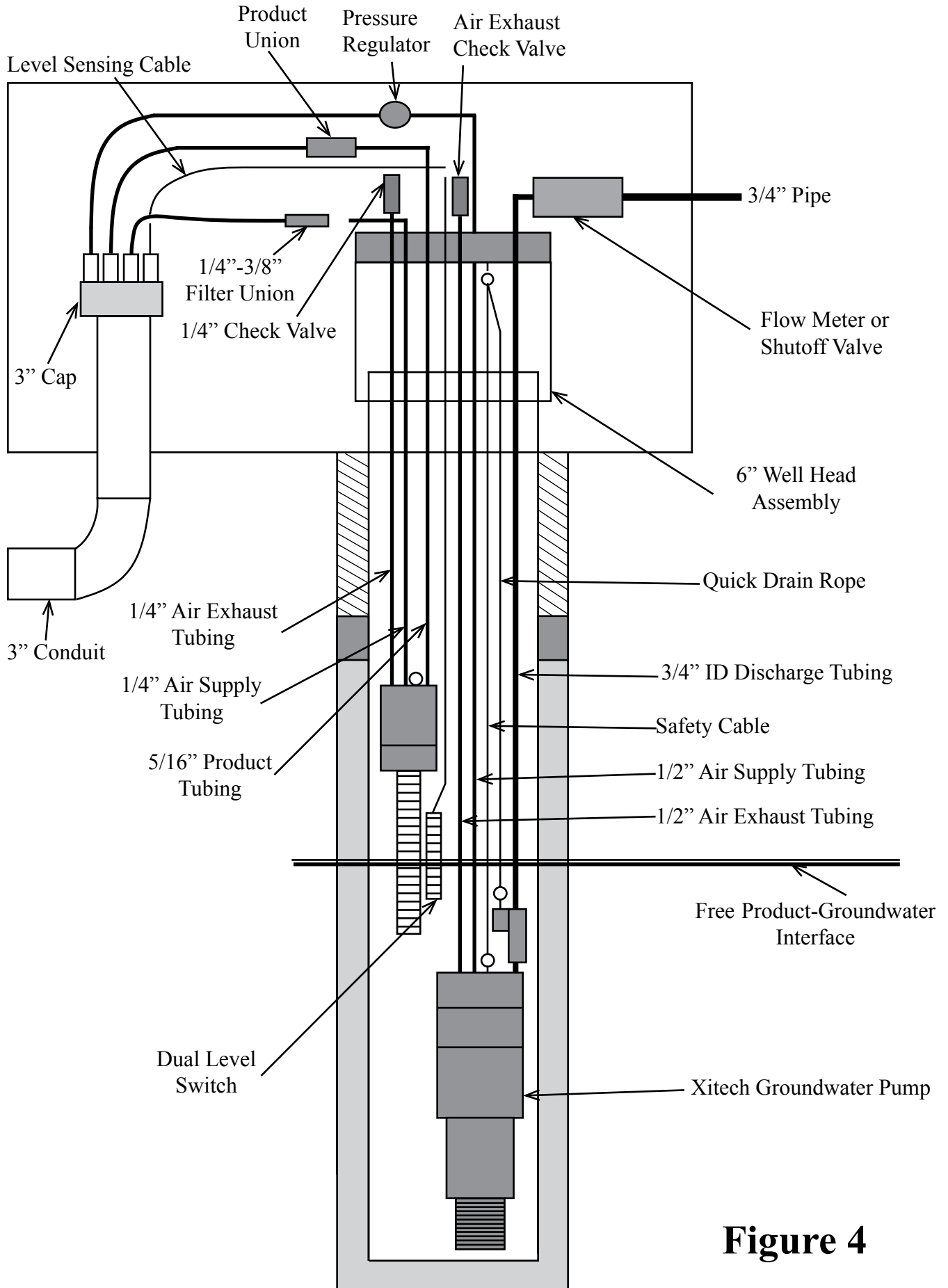
**Figure 2**

# Shallow Trenching



**Figure 3**

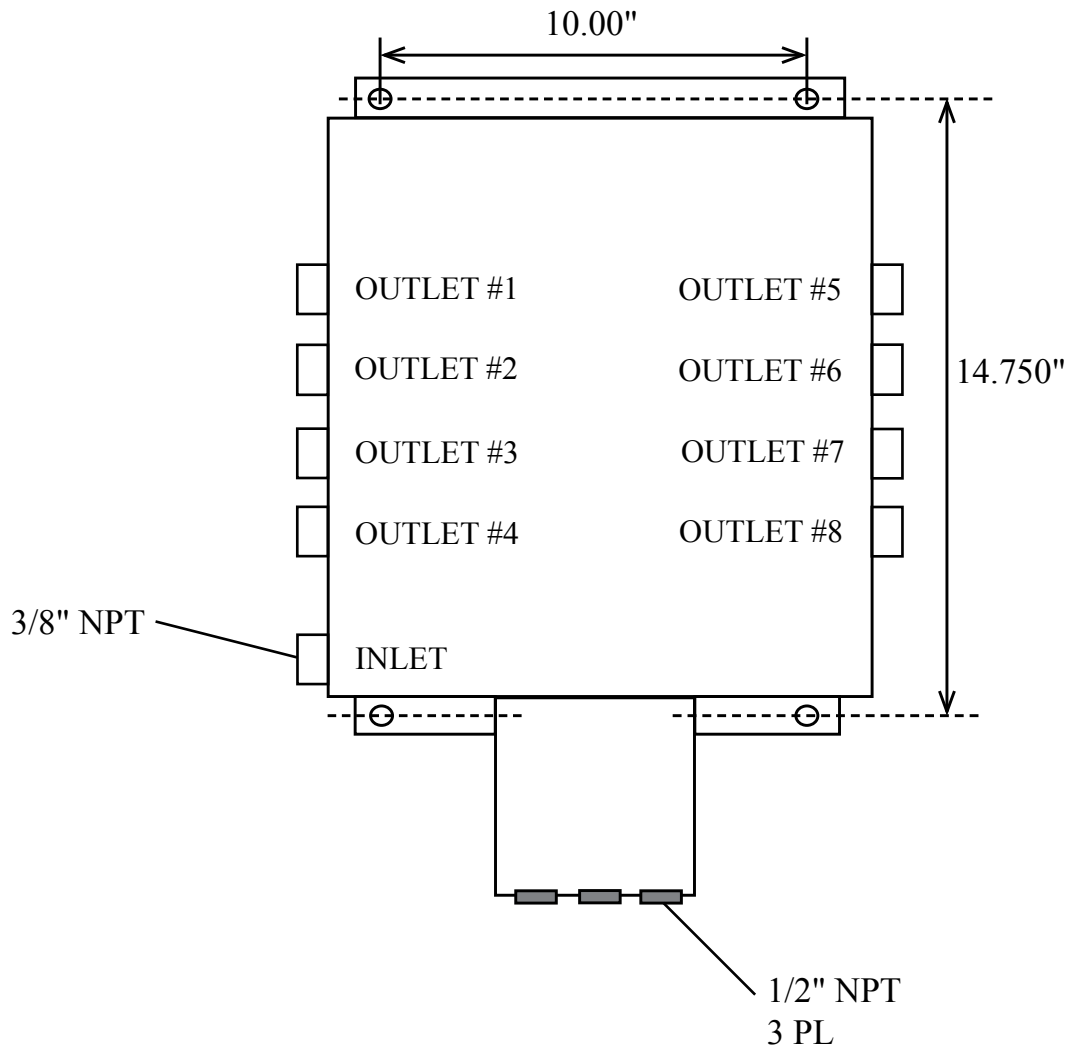
# Deep Trenching



**Figure 4**

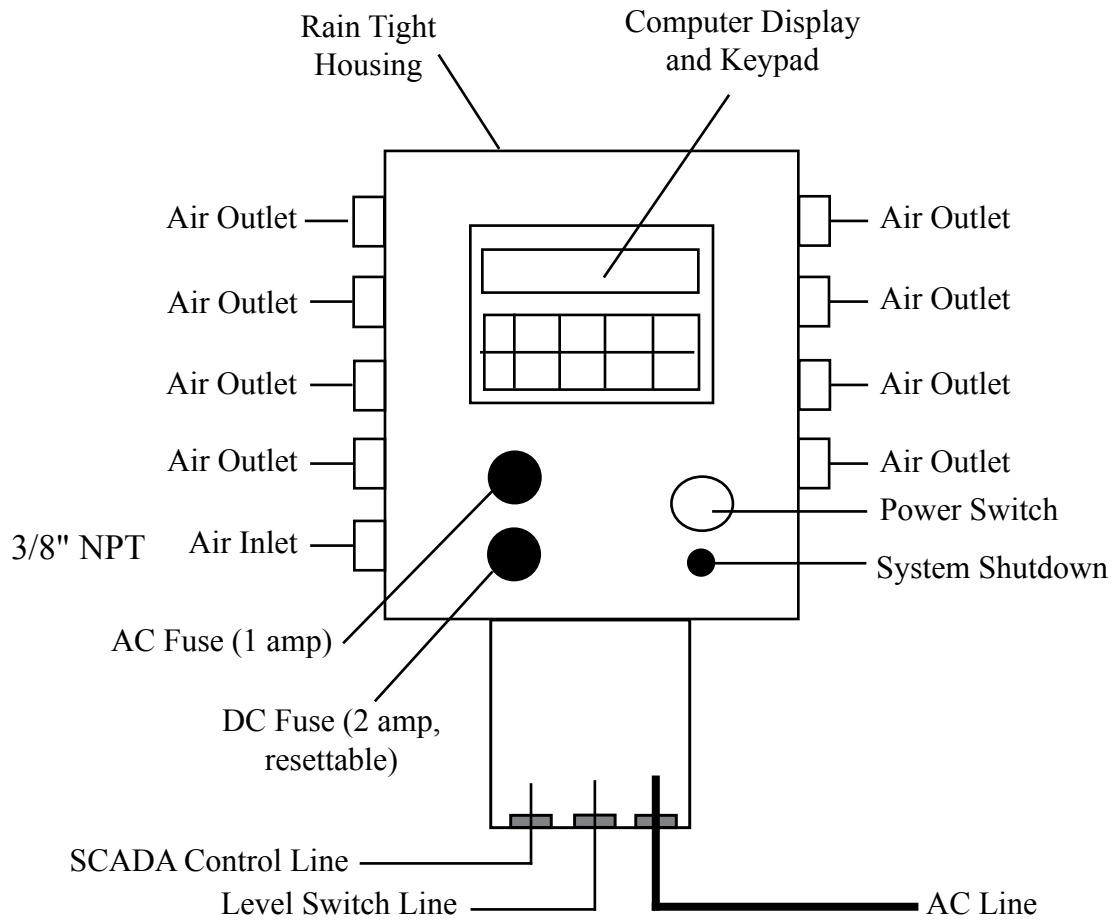
# Xitech Model 5016 or 5015ES Controllers

## Mounting



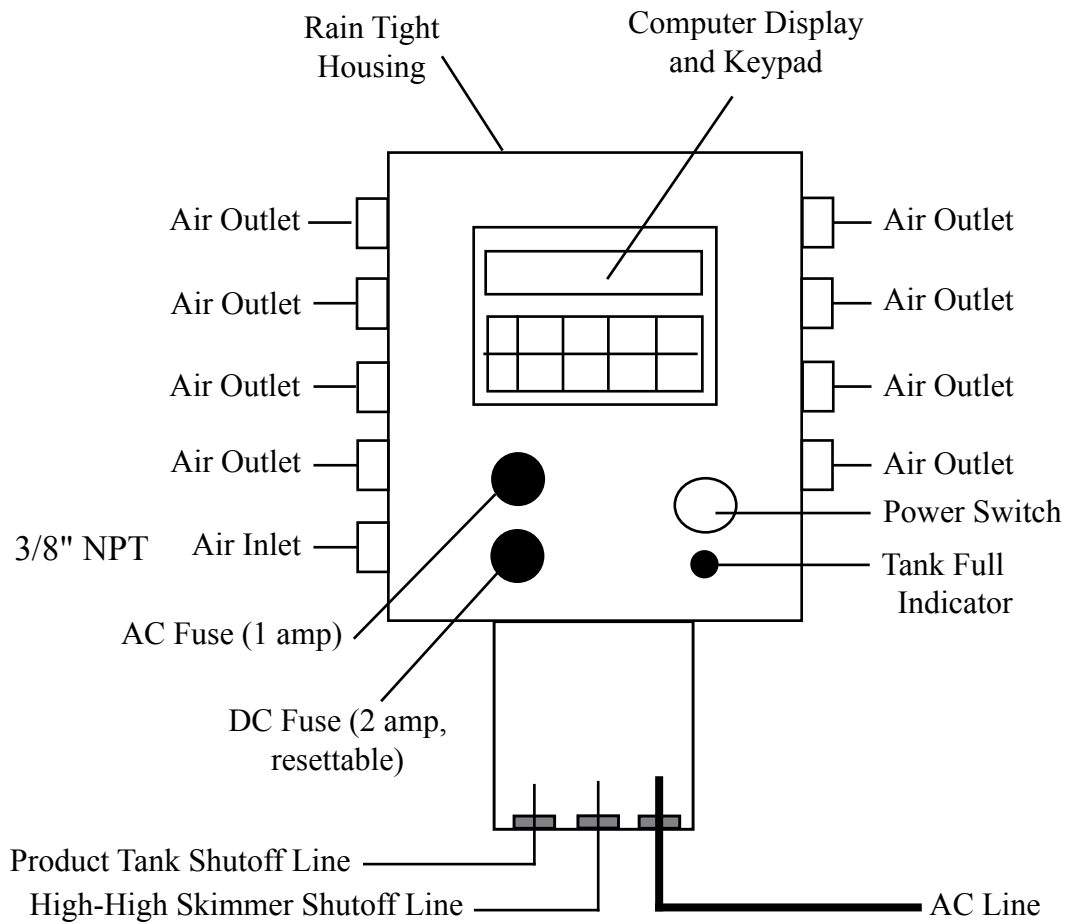
**Figure 5**

# 5016 Pump Controller



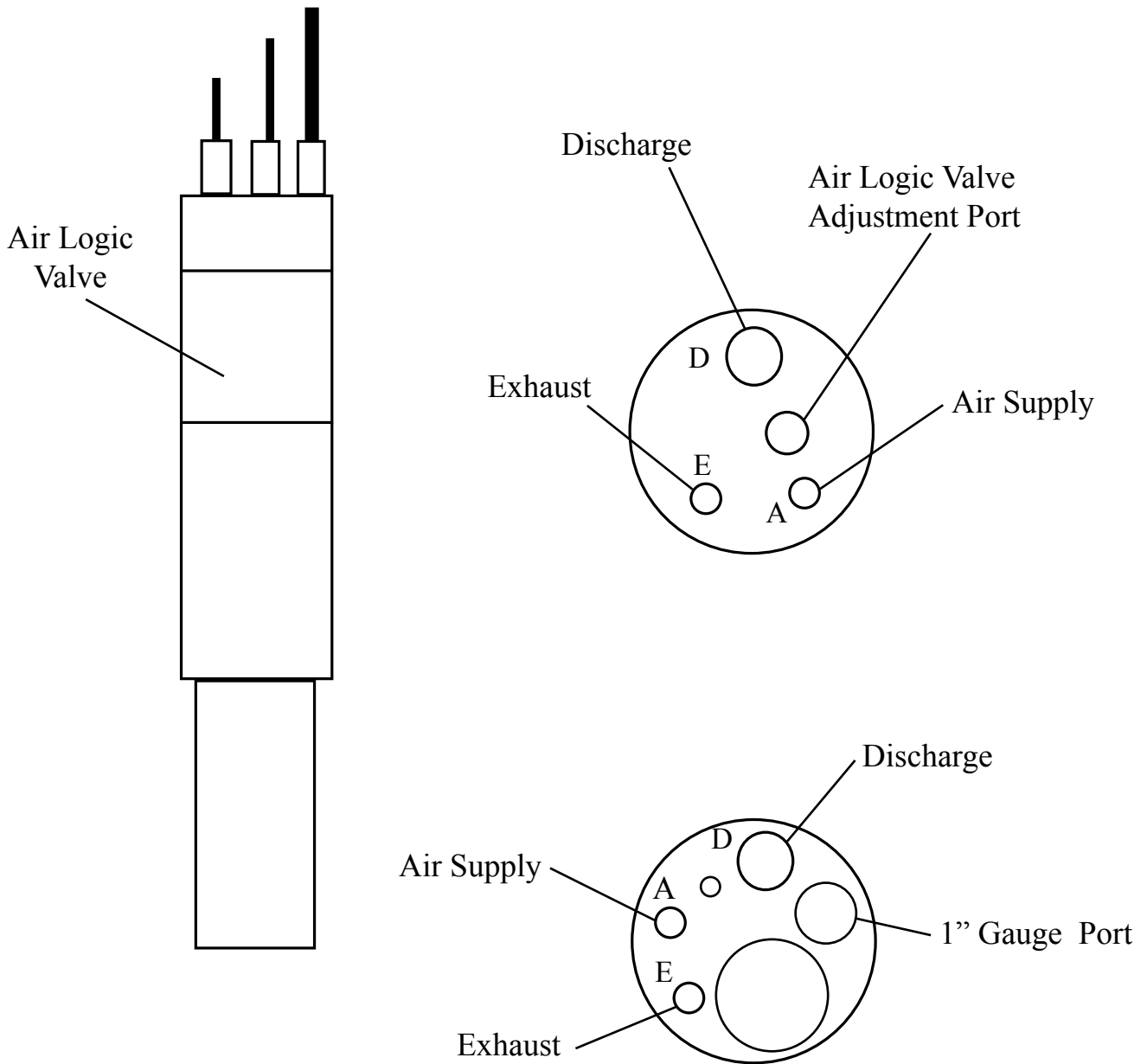
**Figure 6**

# 5015ES Skimmer Controller



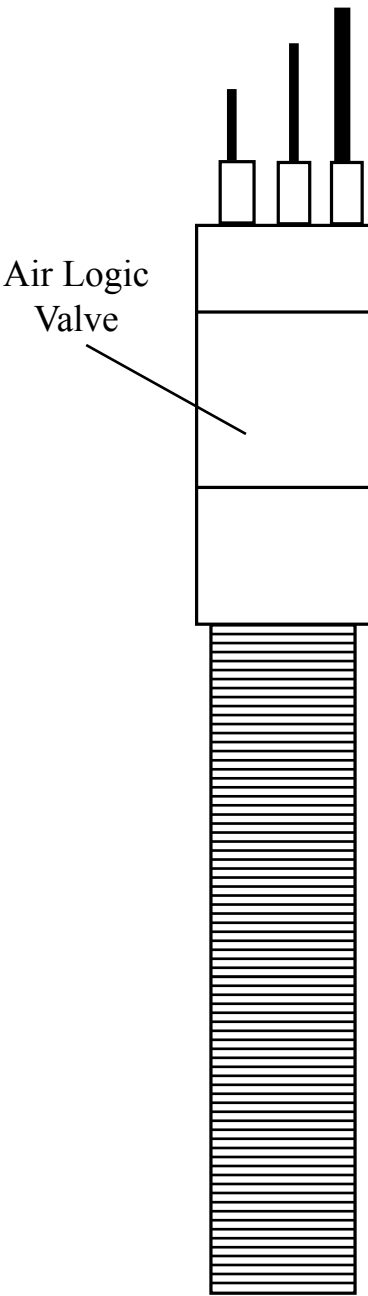
**Figure 7**

# AI400 Groundwater Pump and 6" Well Seal

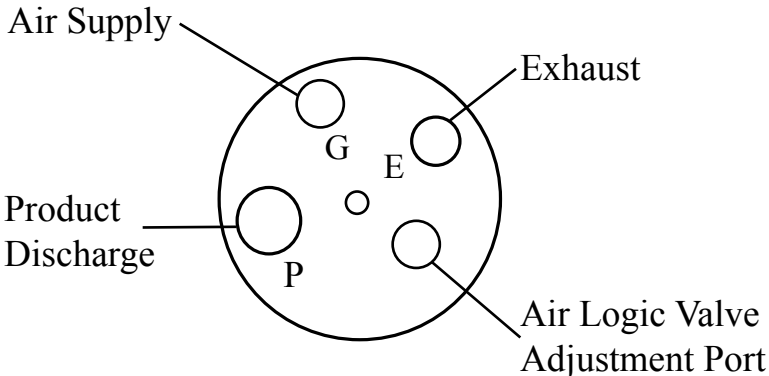


**Figure 8**

# 2" Skimmer and 6" Well Seal



## Skimmer



## 6" Insert Well Seal

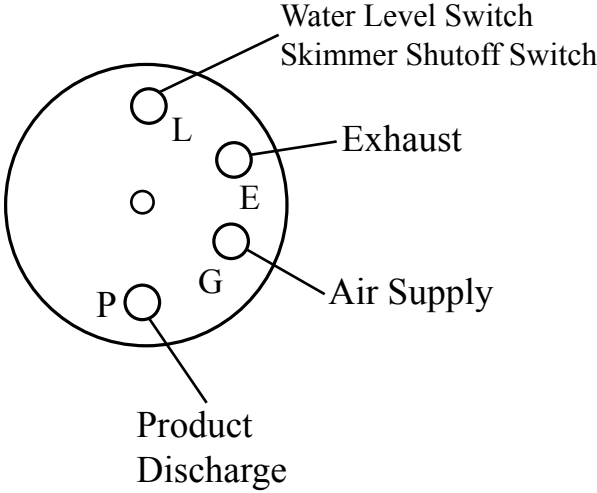


Figure 9