



Installation & Operation Manual

Total Fluids (Single Pump) Recovery with Vacuum

Using Xitech's AI400 Groundwater Pump and 5016 8-Well Controller

Caution:

**Read rules for safe operation and instructions
carefully.**

© Copyright 2010 REV 1/2011

06 Camino De Los Desmontes, Placitas, New Mexico 87043

Phone: 505-867-0008 Fax: 505-867-0212

Web site: www.xitechinc.com

E-mail: xitechinc@xitechinc.com

3 YEAR WARRANTY

This product is warranted to the original purchaser to be free from defective materials and workmanship. Under this warranty the product will be repaired or replaced at our option, without charge for parts or labor.

This warranty does not apply to the air logic valve.

The period of this warranty covers 3 years on parts and labor from date of original purchase.

This warranty entitles the original purchaser to have the warranted parts and labor rendered at no cost for the period of the warranty described above when the instrument is carried or shipped, prepaid, to our factory, together with proof of purchase.

RULES FOR SAFE OPERATION

1. Please review carefully and abide by the maximum limits placed on each type of equipment.
2. Please follow standard electrical practices and safety precautions when installing AC power to our products.

Total Fluids (Single Pump) Recovery With Vacuum

The Xitech Total Fluids Recovery system with vacuum (Figure 1) requires a four inch diameter well or greater. This system includes: an intrinsically safe Auto-Isolator 400 pneumatic Groundwater Pump (Figure 7) which removes groundwater down to 200 feet deep, a programmable Controller Model 5016 which controls up to 8 pumps, and a true interface level switch. The 5016 Controller provides central control of the groundwater pumps, displays several statuses, has individual automatic and manual pump control, shows individual run times for each groundwater pump, and can be controlled by a SCADA computer.

System Installation

STEP 1. Mount the 5016 Controller (Figure 5) in a vertical position near the air source, power source, and other above ground controls if possible. **CAUTION:** The 5016 Controller is NOT intrinsically safe. Do not use in a CLASS I hazardous area.

STEP 2. If a SCADA Controller is present on the site and you wish to have the SCADA be able to shut down our groundwater pumps, attach a two conductor communication cable from the 5016 Controller's junction box (Figure 6) over to the existing SCADA Controller. This communication cable will allow the SCADA computer to automatically turn off all groundwater pumps when necessary. **NOTE:** The SCADA needs to provide the 5016 Controller with a normally CLOSED dry contact switch signal.

STEP 3. Attach a AC 120 volt power source to the controller (Figure 6). Turn on the controller power switch. If the red "Tank Full" light comes on, you have a problem with the SCADA shutoff wiring. Turn off the power switch and recheck the SCADA control switch and wiring. If the light continues to stay on call the factory.

STEP 4. Install an 1/2" OD air supply line from the main air source to the INLET of the 5016 Controller. Do NOT apply air pressure YET. **NOTE:** The air supply needs to be free of WATER and OIL to minimize pump maintenance.

STEP 5. Install an air pressure regulator (Figure 3 or 4) in each well vault. Install a 1/2" OD air supply line from one of the outlets of the 5016 Controller, through the 2" vacuum cap (Figure 2) on the individual vacuum line inside the compound, through the 2" horizontal vacuum line running out to the well vault, through the 2" vacuum cap fitting labeled "A", and over to the inlet of the pressure regulator. **CAUTION:** Please be sure not to have any sharp 90 degree elbows in the 2" vacuum conduit run from the compound to the well vaults. Use 2" swept elbows or two 45 degree elbows, do not use 90 degree elbows.

Total Fluids (Single Pump) Recovery

With Vacuum

STEP 6. Install the level switch wiring cable (Figure 2) from the 5016 Controller junction box out to each well vault inside the 2" vacuum line.

STEP 7. Install horizontal groundwater discharge piping lines $\frac{3}{4}$ " ID or greater to each of the well vaults. Attach a male $\frac{3}{4}$ " NPT pipe fitting onto the end of this line inside each well vault. Attach our $\frac{3}{4}$ " NPT 2-way shutoff valve or the outlet end of our $\frac{3}{4}$ " NPT flowtotalizer and shutoff valve assembly (Figure 3) onto the horizontal discharge piping in the well vault.

STEP 8. Place our groundwater pump and 4" well seal (Figure 7) on the ground near the well. Cut a length of $\frac{3}{4}$ " ID discharge hose to cover the distance from the top of the well down to the top of the pump. Attach one end of the discharge hose to the bottom side of the well seal in the port labeled "D" (Figure 7). Secure this end of the hose with a stainless steel hose clamp. Attach the other end of the discharge hose to the barb fitting on the top of the groundwater pump labeled "D". Secure this end of the hose with a stainless steel hose clamp.

STEP 9. Cut a length of $\frac{3}{4}$ " discharge hose to cover the distance from the top of the well seal over to the inlet of the flowtotalizer or 2-way shutoff valve. Attach one end of the discharge hose to the inlet of the flowtotalizer or 2-way shutoff valve. Secure this end of the hose with a stainless steel hose clamp. Attach other end of the discharge hose to $\frac{3}{4}$ " elbow barb fitting on the top of the well seal labeled "D".

STEP 10. Cut a length of $\frac{1}{2}$ " OD air supply tubing to cover the distance from the top of the well down to the top of the groundwater pump plus 5 feet. CAUTION: Please keep dirt from getting into this line! Slide the tubing through the top of the well seal fitting labeled "A" until 3 feet of tubing is sticking out of the top of the well seal. Attach the long end of the tubing to the top of the groundwater pump barb fitting labeled "A" (Figure 7). Secure this tubing to the barb fitting with a stainless steel hose clamp. Attach the other end of the air supply tubing to the outlet of the pressure regulator.

STEP 11. Cut another length of $\frac{1}{2}$ " OD air exhaust tubing same length as the air supply line. Slide the tubing through the top of the well seal fitting labeled "E" (Figure 7) until 3 feet of tubing is sticking out of the top of the well seal. Attach the long end of the tubing to the top of the groundwater pump barb fitting labeled "E" (Figure 7). Secure tubing to the barb fitting with a stainless steel hose clamp. Attach a $\frac{1}{2}$ " check valve to the other end of the air exhaust line sticking out of the top of the well seal.

Total Fluids (Single Pump) Recovery With Vacuum

STEP 12. Cut a length of safety cable the same length as the air supply line. Secure the safety cable to the underside well seal eyebolt and to the eyebolt on the top of the groundwater pump using two stainless steel clamps at each end.

STEP 13. Attach the water level switch assembly (Figures 3 and 4) to the bottom of the pump using two metal hose clamps. Slide the level switch cable through the bottom of the well seal fitting labeled “L” (Figure 7) until 5 feet of the level switch cable is sticking out of the top of the well seal. Slide the end of the level switch cable coming out of the top of the well seal through the 2” conduit cap fitting labeled “L” until 1 foot of the cable is sticking through the 2” conduit cap. Attach the wires from the level switch cable to the grey level switch wire cable in the horizontal 2” conduit.

STEP 14. Cut a length of drain rope the same length as the air supply line. Attach this rope to the drain valve ring at the top of the groundwater pump and to the eyebolt located on the underside of the well seal.

YOU ARE NOW READY TO INSTALL THE PUMP INTO THE WELL.

Repeat STEPS 8 - 14 for all of the groundwater pumps. Install all of the groundwater pumps into the wells. Installation of the system is now ready to operate.

System Operation

Operating air supply pressure limits:

Minimum operating pressure is 50 psi.

Maximum operating pressure is 150 psi.

Note: You must be able observe the fluids inside the discharge line, to proceed.

STEP 1. Go to the manual control window in the Xitech 5016 Pump Controller. Turn on the pump.

STEP 2. Adjust (increase) the pressure regulator at the well until you observe free product in the discharge line.

Total Fluids (Single Pump) Recovery With Vacuum

NOTE: Observe how much pressure it takes to start depressing the water level. You want the water level to drop slowly. If you do not observe free product within 2 minutes increase the pressure 10 psi.

STEP 3. Once you have set the discharge flow rate of the pump. Turn off the pump at the 5016 Controller. Allow the water to completely recover to the static level.

STEP 4. Turn on the AI-400 pump at the 5016 Controller. Record the time it takes to observe when air bubbles begin showing up in the free product.

NOTE: It is best to make the pumping time a little shorter than the total time it takes to see bubbles in the discharge line to prevent air from mixing with the pumped liquids. Air causes bio, iron or calcium fouling in the above treatment system.

STEP 5. Turn off the pump at the 5016 Controller.

STEP 6. Go to the programming window and input the time in the duration field.

NOTE: If it took 15 minutes to see air bubbles in the free product. Then input 12 minutes of pumping time.

STEP 7. Repeat steps 1 - 6 for all other wells. When finished programming, return to the STATUS Window to activate the pumping program.

NOTE: Regular observation of the discharge line at the well for air bubbles will insure optimum recovery of the LNAPL and minimize above ground fouling.

Total Fluids (Single Pump) Recovery With Vacuum

Explanation of the 5016 Software Windows

WINDOW #1: This is the first window of four windows. Here you can observe the status of each of the 8 outlet stations and the elapsed run of each outlet station. You can also reset the elapsed run time for any station in this window. There are five different statuses that can show in this window: Inactive, Pump Off, Pump On, System Off, Low Battery.

Inactive: There is no program for this station.

Pump Off: There is a program and the controller is waiting for a level switch signal to turn on the pump.

Pump On: The pump should be running.

System Off: The controller has received a shut down signal from the SCADA computer. All stations should be off.

Low Battery: The backup batteries in the PLC computer preserves the program data. When AC power is lost and the batteries are low and need replacing.

WINDOW #2: This window is where you program the pumping duration time: the longer the time, the deeper the water depression.

WINDOW #3: This window also has a setting for turning off the outside SCADA input signal. CAUTION: When the Level Sensor is OFF, the 5016 Controller will NOT look for an outside SCADA control signal.

WINDOW #4: This window is used to temporarily override any of the 8 stations' present states. OFF means this station is not running. ON means this station is running. Any changes you make in this window will go away when you leave this window.

Total Fluids (Single Pump) Recovery With Vacuum

Key Pad Descriptions

MENU: This Key changes windows.

The left and right arrow Keys move the cursor to the next programmable field.

The up arrow Key increases the value in the field the cursor is on.

The down arrow Key decreases the value in the field the cursor is on.

TIME RESET: This Key will reset the elapsed run time of a station when you are in the STATUS WINDOW.

REV: This Key is to show you what software version is currently being used by your computer.

DEL: This Key will replace all programmed values with preset default values. This Key will NOT delete the elapsed run times.

Total Fluids (Single Pump) Recovery with Vacuum Individual Air Supply and Common Discharge Return

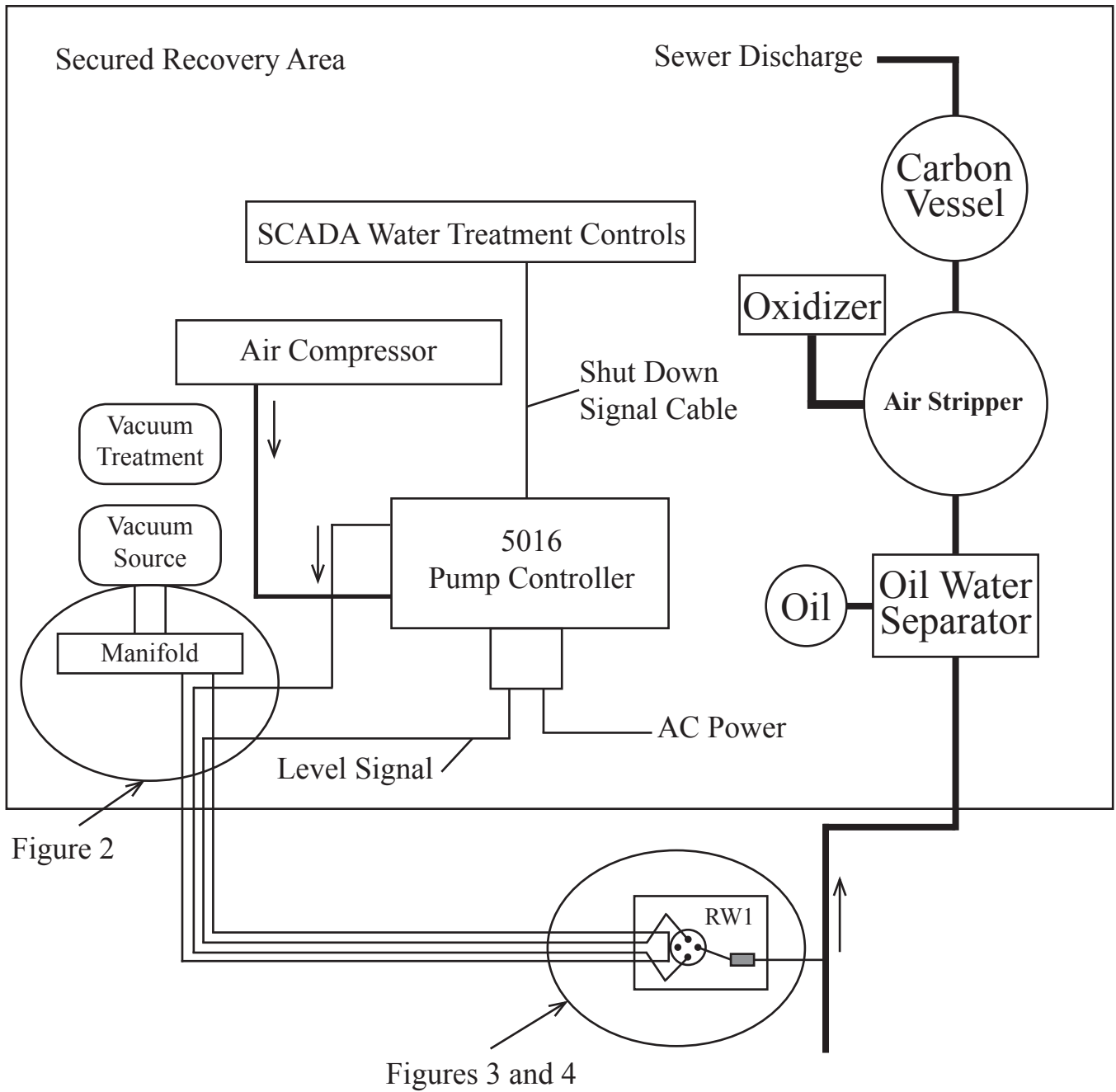

Figure 1

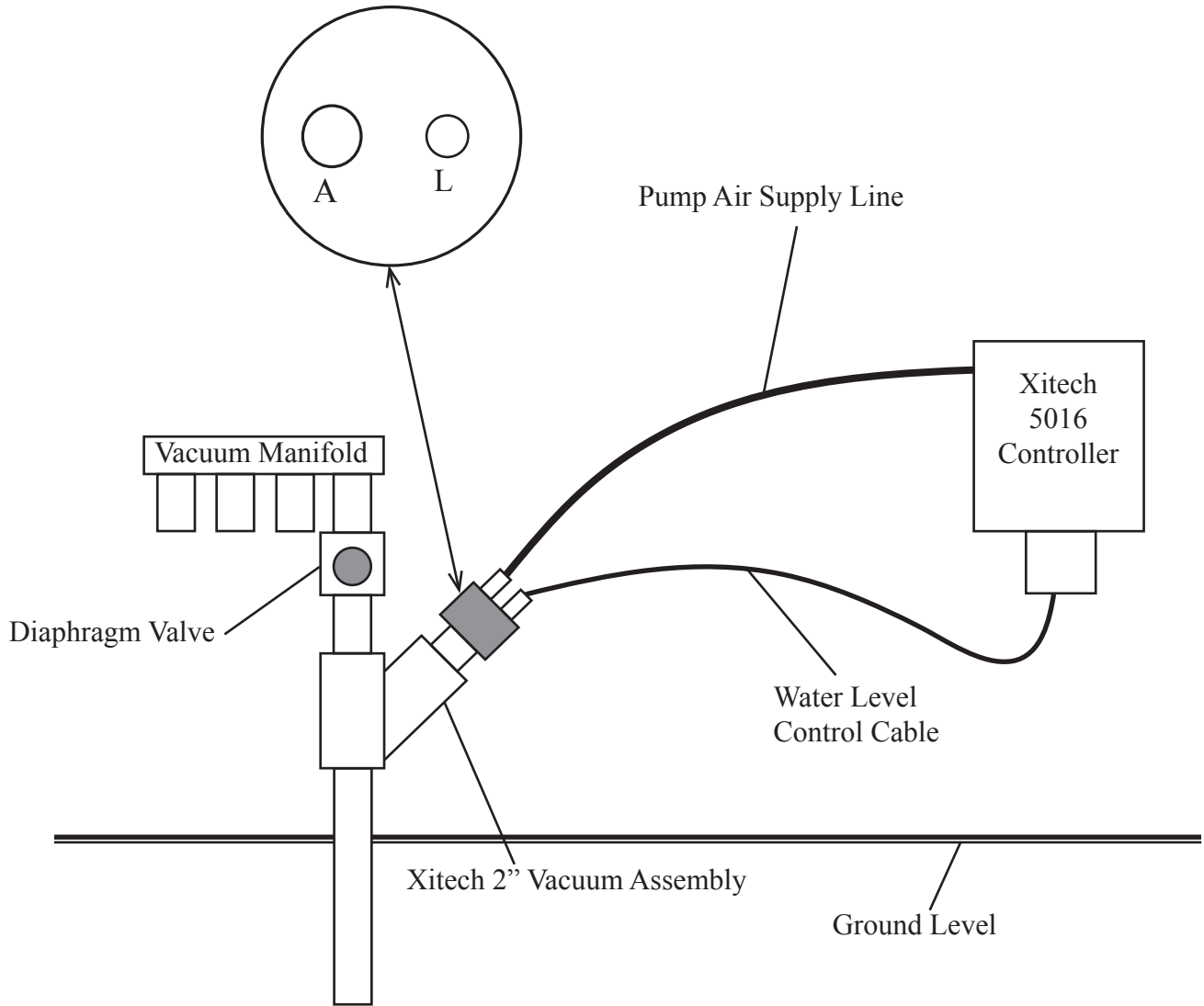

Figure 2

Shallow Trenching

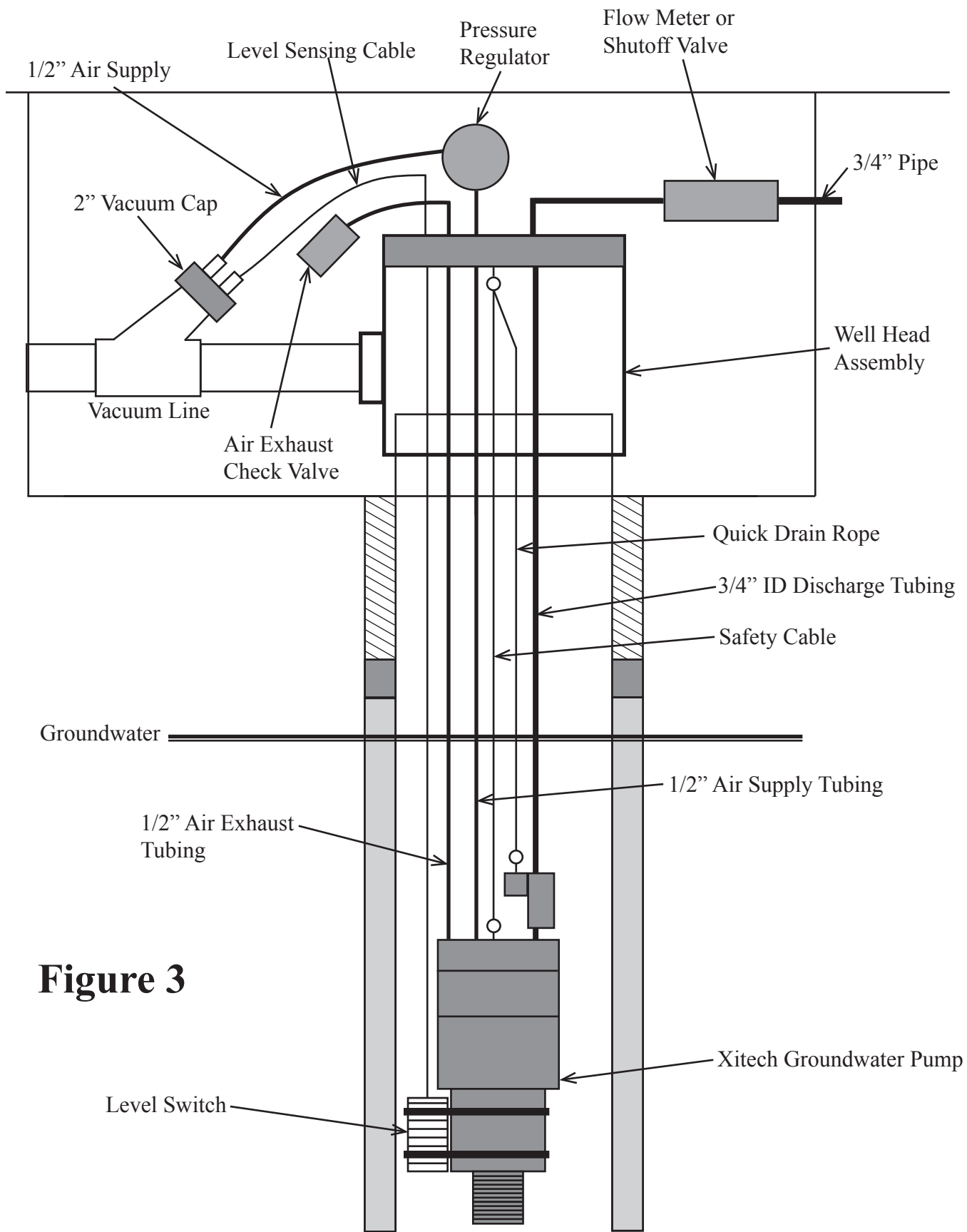

Figure 3

Deep Trenching

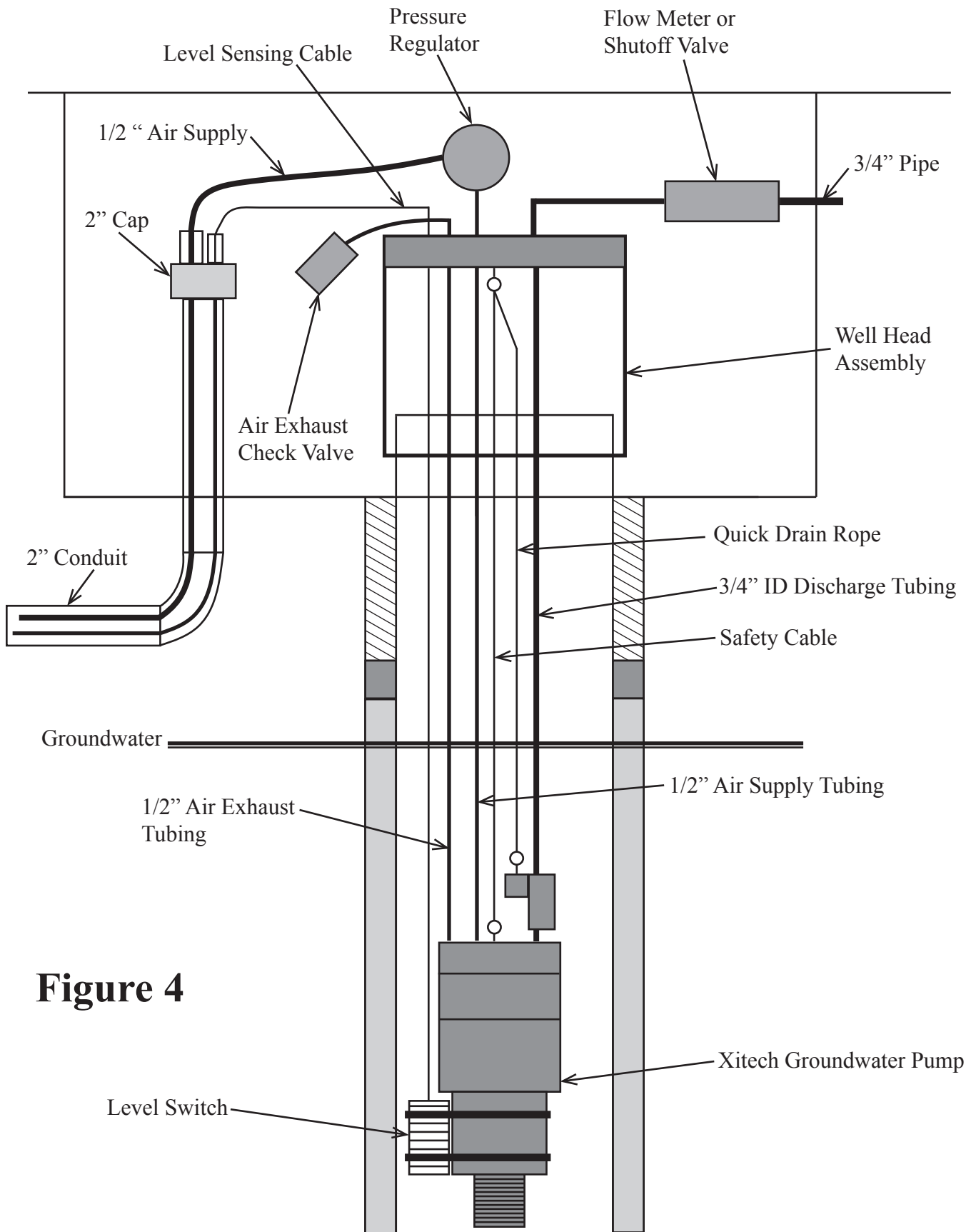

Figure 4

Xitech Model 5016 Controller Mounting

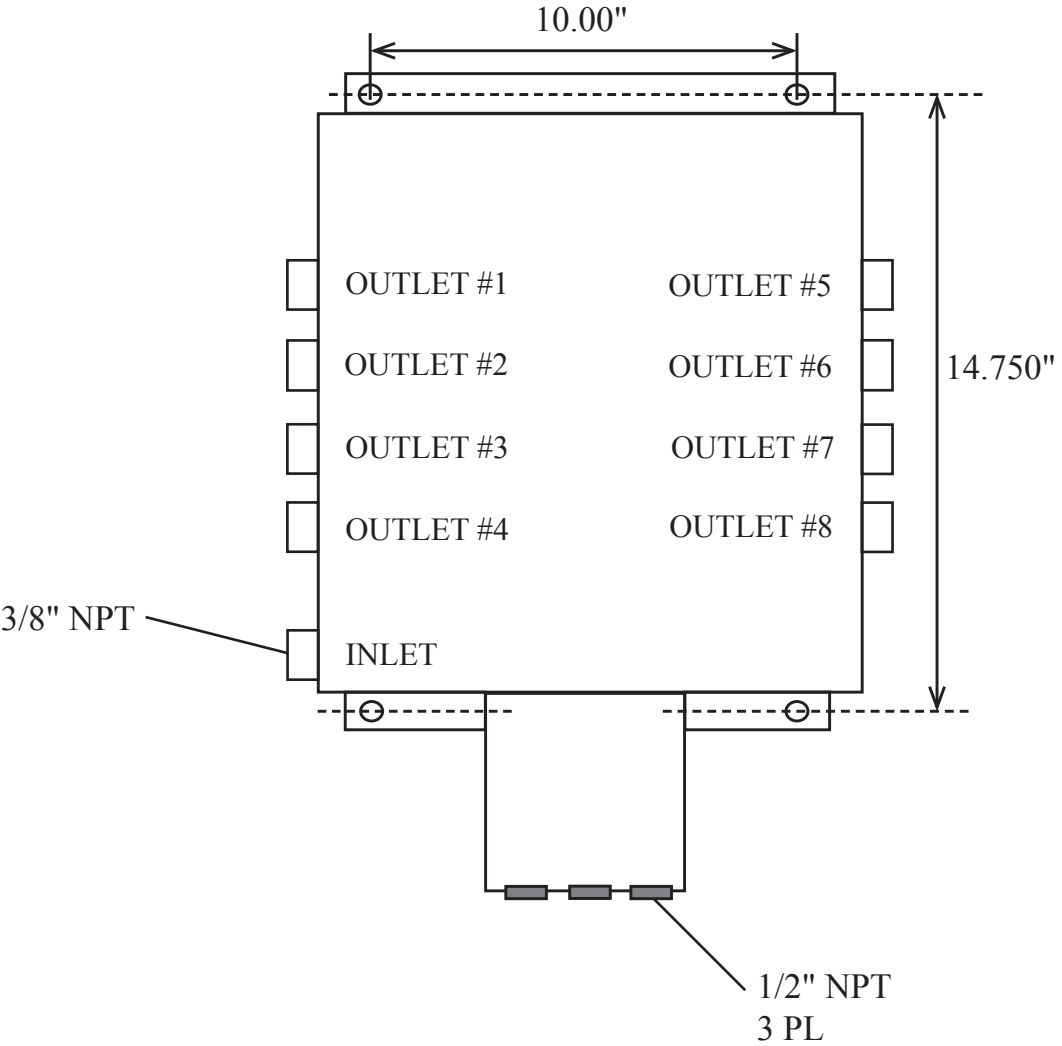

Figure 5

5016 Pump Controller

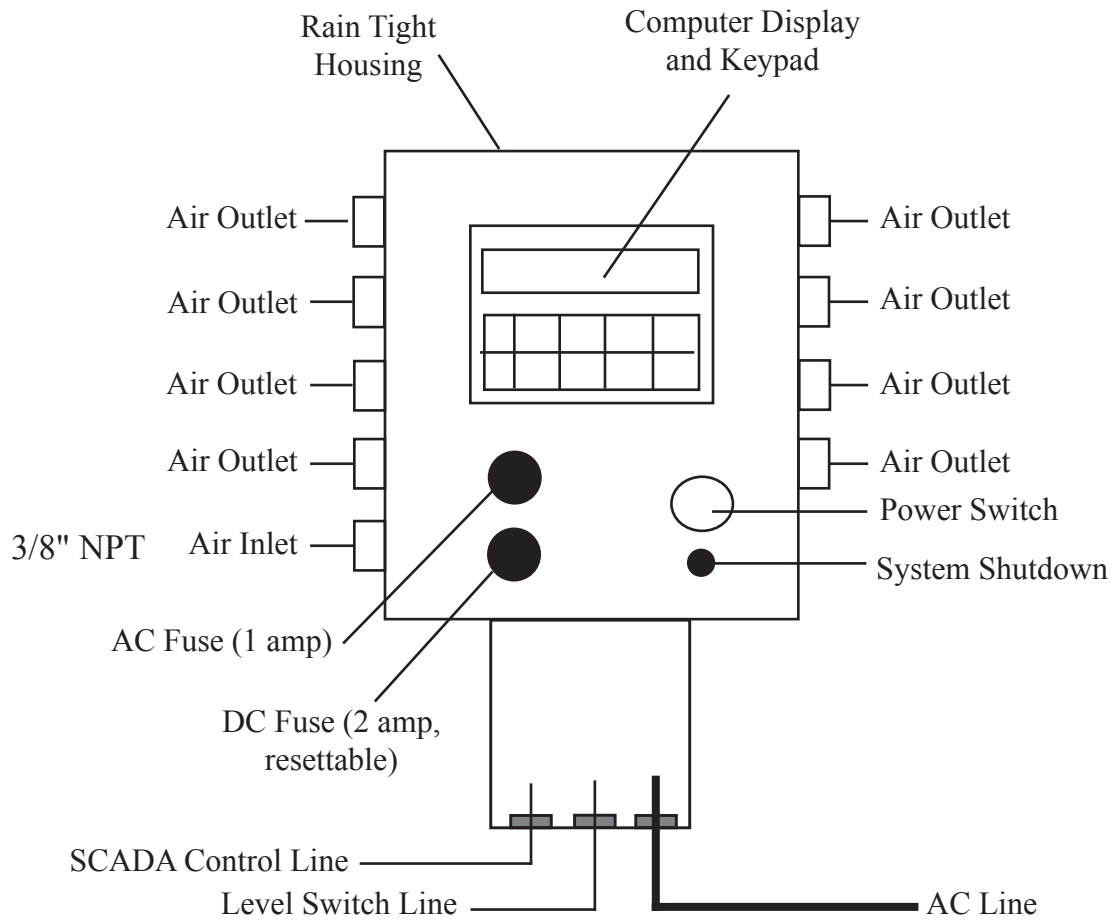

Figure 6

AI400 Groundwater Pump and 4" Well Seal

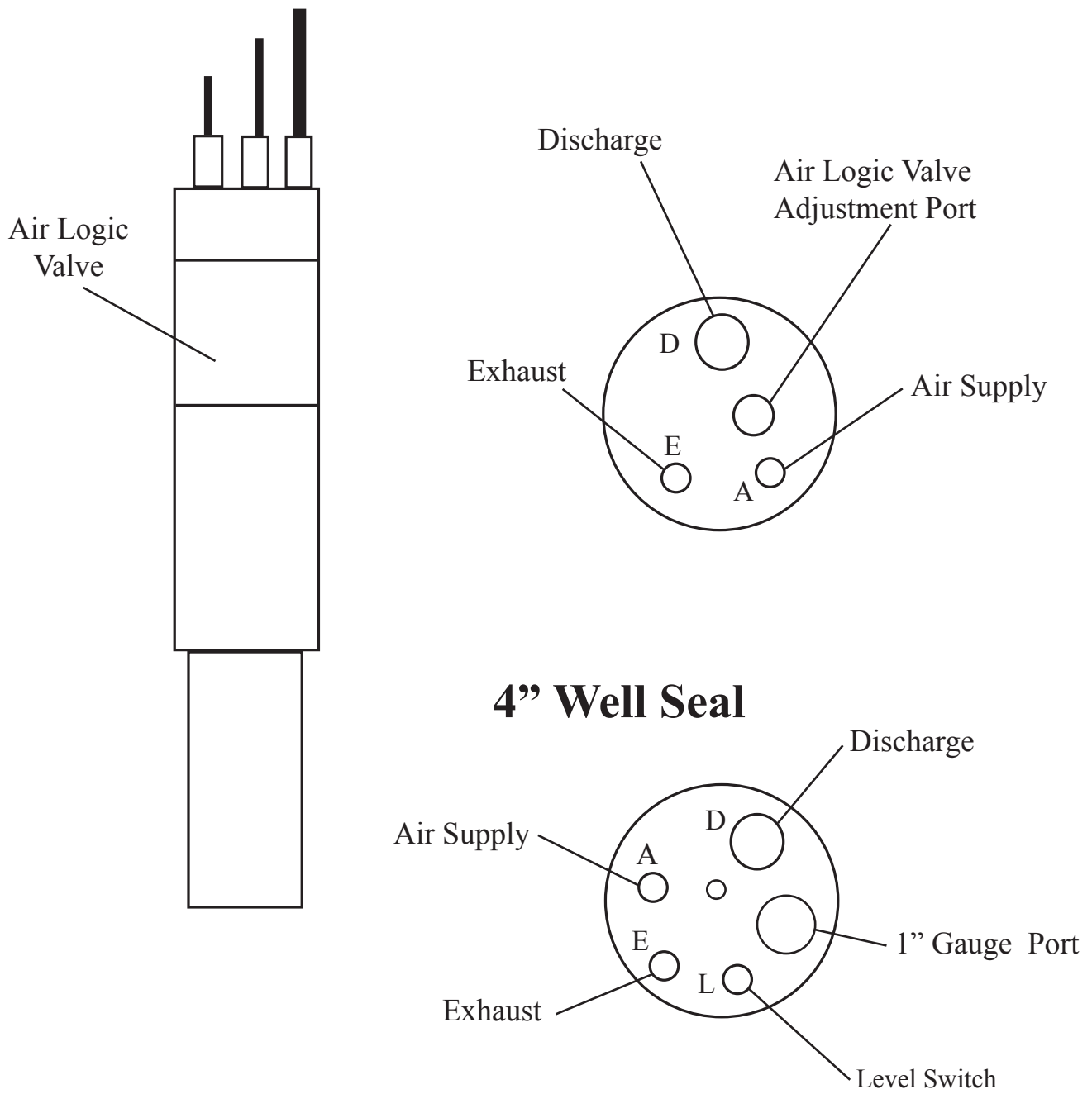

Figure 7