

ADJ200 Smart Skimmer and 3000ES Programmable Controller Single Skimmer Operations Manual

Caution:

**Read rules for safe operation and instructions
carefully.**

© Copyright 2004 REV 07/2010

XITECH
Instruments, Inc.

06 Camino De Los Desmontes, Placitas, New Mexico 87043

Phone: 505-867-0008 Fax: 505-867-0212

Web site: www.xitechinc.com

E-mail: xitechinc@xitechinc.com

3 YEAR WARRANTY

This product is warranted to the original purchaser to be free from defective materials and workmanship. Under this warranty the product will be repaired or replaced at our option, without charge for parts or labor.

This warranty does not apply to the skimmer hydrophobic filter or air logic valve.

The period of this warranty covers 3 years on parts and labor from date of original purchase.

This warranty entitles the original purchaser to have the warranted parts and labor rendered at no cost for the period of the warranty described above when the instrument is carried or shipped, pre-paid, to our factory, together with proof of purchase.

RULES FOR SAFE OPERATION

- 1. Please review carefully and abide by the maximum limits placed on each type of equipment.**
- 2. Please follow standard electrical practices and safety precautions when installing AC or DC power to our products.**

3000ES Controller Specifications

The 3000ES programmable controller brings absolute operating control over any Xitech skimmer. The 3000ES is an excellent choice for remote solar powered operations due to its ability to be programmed for day-time operations. The 3000ES software is user friendly and fast to program. The interval programming software enables users to select up to 24 start times in a day, up to 99 minutes of run time for each start time, and up to 30 days delay for one interval. The computer also keeps track of total run time of the skimmer. The software also includes a manual operation choice for easy direct control of the skimmer. The 3000ES can easily accommodate up to 2 Xitech Smart Skimmers and can be operated on AC or DC power source. The 3000ES computer is housed in a weather-proof housing and includes a high tank shut-off assembly. Timer panel indicates a tank full with a RED light.

Specifications:

Programmable intermittent control 24 start times with up to 99 minutes of run time

30 days delay for one interval

Visual indicator displays tank full condition

Battery backed program memory

Power: 12 volt DC, 110 AC or 220 AC

Maximum air pressure: 125 psi

Weather-proof housing

Size: 8"H X 6"W X 4"D

Order No. 3000ES

Product Recovery System Installation

The system (Figure 1) relates to floating hydrocarbon recovery in wells two inches in diameter and larger. This system includes: an intrinsically safe ADJ200 pneumatic Smart Skimmer (Figure 2) which removes only the product to a sheen down to 200 feet deep; and a three function programmable Controller Model 3000ES which operates the skimmer intermittently, records run time, and has a high level tank shutoff.

STEP 1. Mount programmable Controller Model 3000ES (Figure 3) in a vertical position near the air source, power source, and holding tank if possible. CAUTION: The Model 3000ES is NOT intrinsically safe. If this controller must operate in a CLASS I area, use the XITECH Model 2550ES CLASS I Controller instead. Air supply needs to be free of WATER and OIL to have minimum maintenance. NOTE: The ON/OFF switch inside the controller is for AC and DC power.

STEP 2. Install holding tank shutoff assembly into holding tank (a 2" standard pipe inlet will be required in the holding tank). The level of product in the holding tank can be set by raising or lowering the liquid level float switch rod. Wire the shutoff switch cable into the controller (Figure 3). NOTE: If additional signal cable is needed to position the holding tank assembly further away from the controller, use 18 gauge 2-conductor wire.

STEP 3. Attach power line from the AC or DC power source to the controller (Figure 3). Turn on the controller power switch. If the red "Product Tank Full" light stays on, you have a problem with tank shut-off wiring. Turn off the power switch and re-check the tank shutoff wiring. If the light continues to stay on, call the factory.

If you plan to operate this controller for a long period of time on a DC power source, we suggest you use a solar panel (see page 12 for installation) to maintain power in the battery.

ADJ200 Smart Skimmer and 3000ES Controller with Tank Shutoff

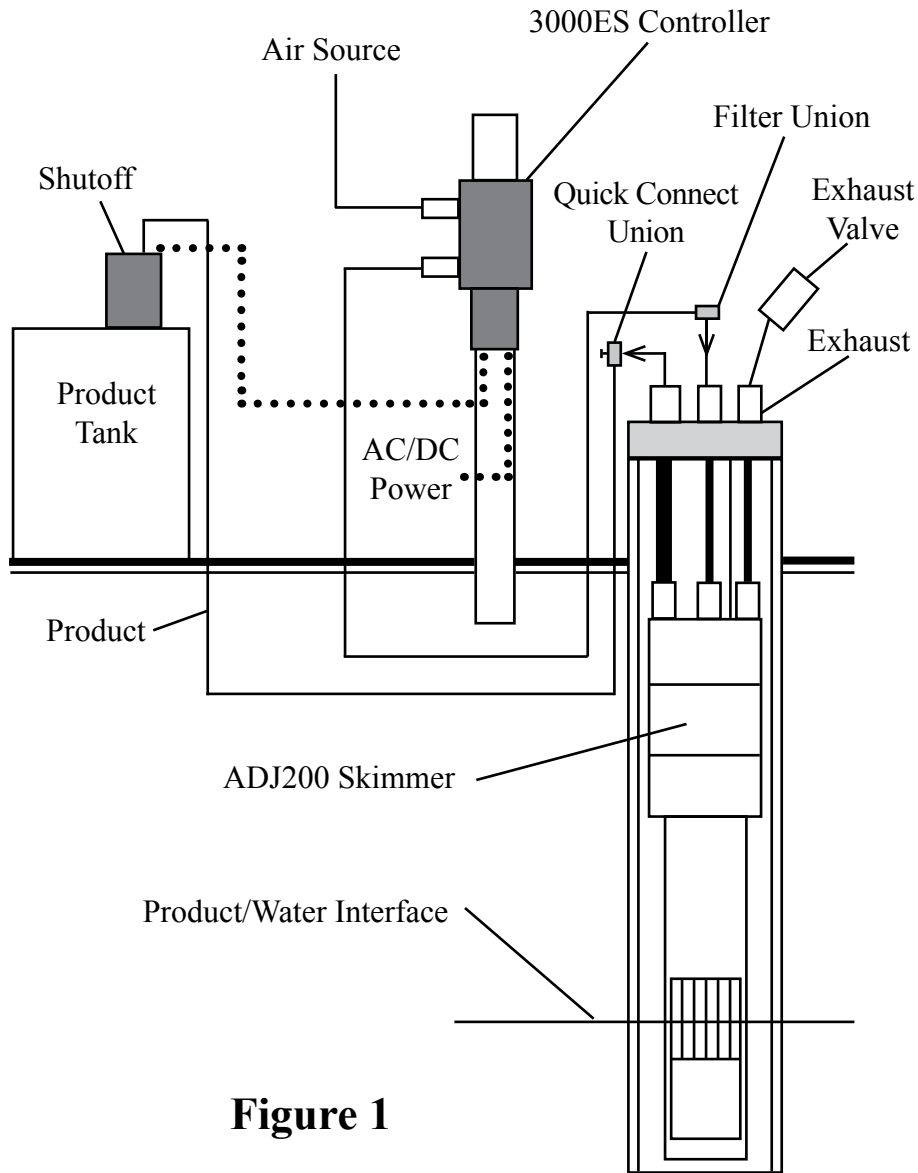

Figure 1

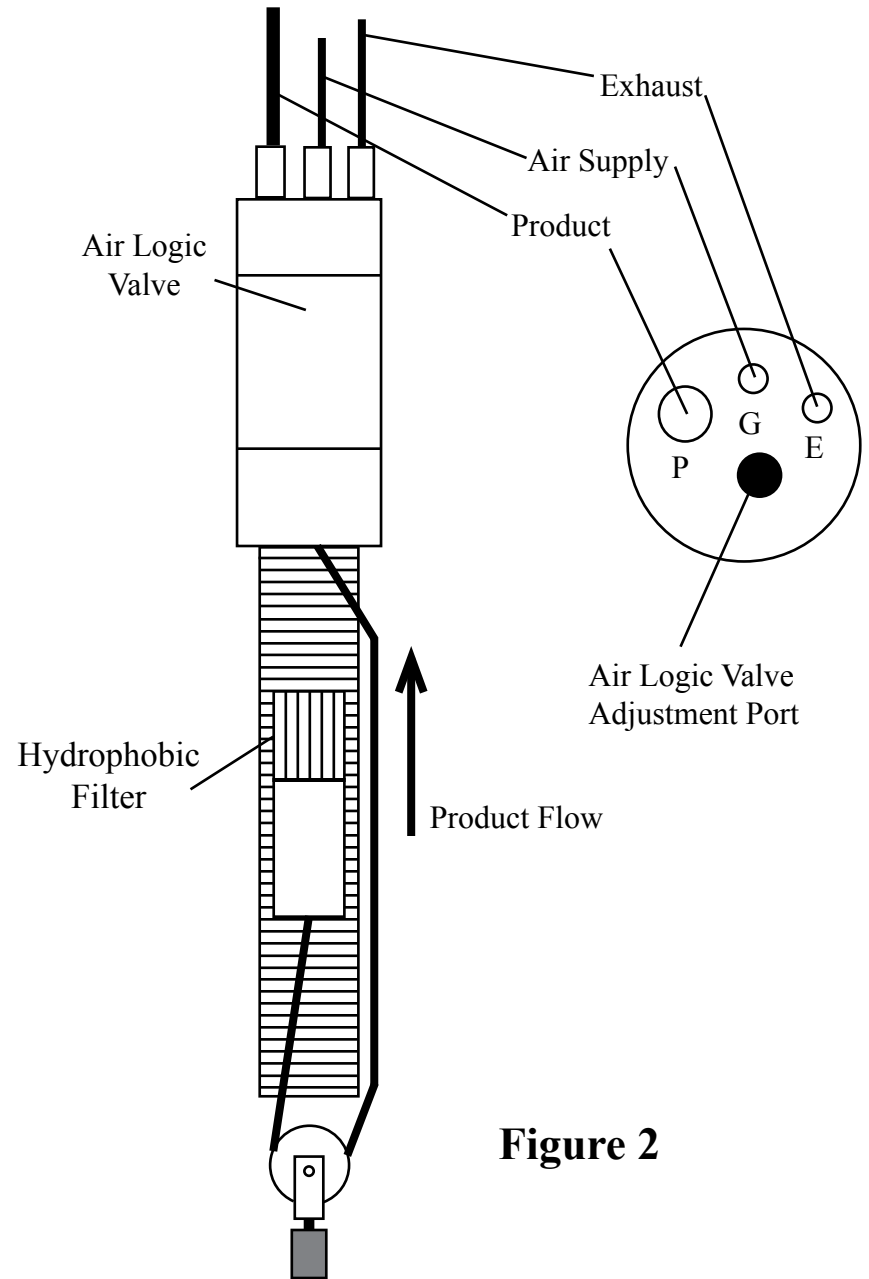

Figure 2

STEP 4. Install 3/8" OD air supply tubing from the main air source to the INLET of the Controller. Do NOT apply air pressure YET.

STEP 5. Install horizontal air supply line to the well. Use 3/8" OD tubing for the horizontal run. **CAUTION:** Please keep dirt from getting into these lines! Attach a filter union onto the end of this line at the well vault.

STEP 6. Install horizontal product return line to the well. Use 1/2" OD tubing for the horizontal run. Attach a quick connect union onto the end of this line at the well vault.

STEP 7. Position the skimmer and well cap on the ground near the well. Cut a length of 1/4" OD air supply tubing to cover the distance from the top of the well down to water/product interface, plus 5 feet. **NOTE:** If the skimmer is over 70 feet deep, use 3/8" OD air supply tubing in stead of 1/4" OD tubing. Slide enough tubing through the well cap and attach the end of the tubing to the top of the skimmer tube fitting labeled "G" (Figure 2). If the product thickness is greater than 1 foot, position the skimmer's "Black Reference Line" on skimmer well screen 1 foot below top of product. If the product thickness is less than 1 foot, position the skimmer's "Black Reference Line" on skimmer well screen at the water/product interface.

STEP 8. Cut a length of 5/16" OD product tubing same length as the air supply line. Install 5/16" OD product tubing through the well cap tube fitting labeled "P" (Figure 2). Slide enough tubing through the well cap and attach the end of the tubing to the top of the skimmer tube fitting labeled "P". **CAUTION:** Do not kink the tubing.

STEP 9. Cut another length of 1/4" OD air exhaust tubing same length as air supply line. Install 1/4" OD air exhaust tubing through the well cap tube fitting labeled "E". Slide enough tubing through the well cap and attach the end of the tubing to the top of the skimmer tube fitting labeled "E".

3000ES Controller

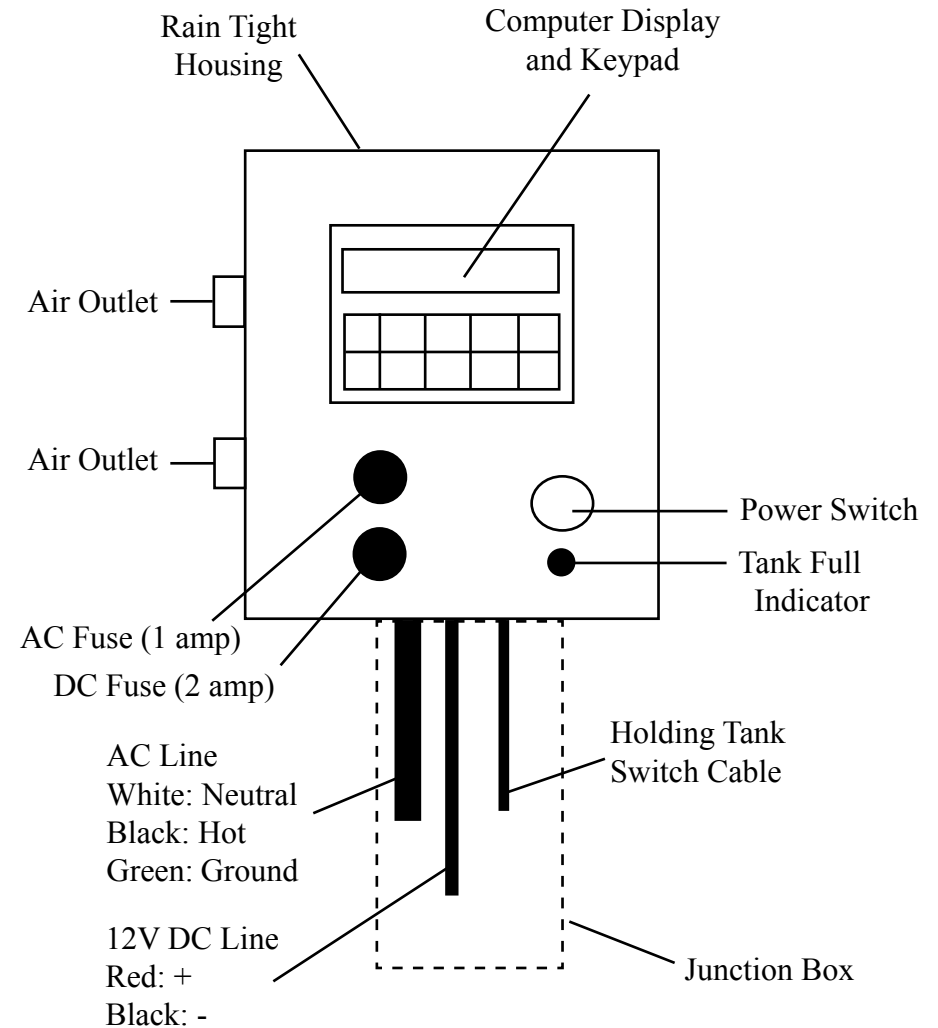

Figure 3

STEP 10. Cut a length of safety rope same length as air supply line. Attach the safety rope from inside the well cap to the top of the skimmer head. The tubing will carry the weight of the skimmer.

STEP 11. Attach the 3/8"-1/4" filter union onto the 1/4" air supply line coming out of the well cap.

STEP 12. Attach the 5/16" product line coming from the well cap into the inlet of the quick connect union.

STEP 13. Attach the exhaust check valve onto the end of the 1/4" air exhaust line coming out of the well cap.

STEP 14. Set operating air supply pressure.

$$\text{AIR PRESSURE} = 70 + \frac{\text{Total Vertical Lift}}{2.85}$$

Minimum operating pressure is 70 PSI

Maximum operating pressure is 125 PSI

STEP 15. Manual operation of skimmer. Push the Manual Key to turn on the skimmer (refer to pages 8 -11 for instructions). Observe that the skimmer is making a pumping noise. The exhaust check valve should have an intermittent pulsing sound about once every second.

STEP 16. While the skimmer is running at the desired operating air pressure above ground, confirm or adjust skimmer pulse rate. To adjust skimmer pulse rate, remove small plug at the top of the skimmer pump head and insert a small flat-head screwdriver into the air logic valve located inside the pump head. Turn clockwise to decrease pulse rate. **NOTE:** Factory sets skimmer pulse rate to 60 pulses per minute at 70 psi operating pressure. Maximum recommended pulse rate is 100 pulses per minute. Lower pulse rates will consume less air.

STEP 17. You are now ready to install skimmer in the well. CAUTION: Please remove skimmer float shipping tie wraps before placing skimmer in well.

Operation of the Product Recovery System

Determine how long it takes for each skimmer to remove all product from the well by using the Manual Control Mode Window. If your skimmer is less than 30 feet deep, product should show up above ground in about 2 minutes.

Observe the product being discharged by the skimmer. Be sure no water is being pumped. If water does appear, pull the skimmer out of the well and check to see if the shipping tie wraps have been removed from the skimmer well screen area. If there are no tie wraps, give Xitech a call toll free at 888-867-9483.

Record the amount of time it takes to empty the well of product. When the well is empty of product, turn off the skimmer.

Determine or guess how long it will take for the product thickness in the well to return to its original thickness. For ease of system observation we suggest that you run only one well at a time and that you have the nearest well run first, the next nearest well run next and so on.

To set up the program.

STEP 1. Start by going to the "PROGRAM OR RUN" window. Push the "DEL" key once. Select "PROGRAM" and push the "MENU" key once to move to the next window.

STEP 2. Input the current clock time. This time is your real time clock time. Push the "MENU" key once to move to the next window.

STEP 3. You should be looking at “#01 START AT: 00:00” window. This is the first interval for operating the skimmer. You can add up to 24 intervals in this controller. Input your START TIME and RUN TIME for all desired intervals before moving to the next window. Push the “MENU” key once to move to the next window.

NOTE: If you found it took 10 minutes to pump the product off, set the “pumping time” to 5 minutes (Xitech’s 1/2 Rule).

STEP 4. Choose how often you would like the interval(s) to run. **NOTE:** If the recovery rate of a well takes longer than a day (i.e. every 2 days). Then you would choose “EVERY OTHER DAY”. Push the “MENU” key once to move to the next window. **NOTE:** A good guess would be once a day for slow recovering product and 3-6 times a day for fast recovering product.

NOTE: Keep in mind that you are always trying to match the recovery rate of product coming into the well from the formation. It is not good practice to operate skimmers faster than the formation recovery rate.

STEP 5. You are now back at the “PROGRAM OR RUN” window. Select the “RUN” choice and push the “MENU” button. You should be looking at “AUTO PUMP OFF” or “AUTO #1 PUMP ON”, depending on your start time. The program is now running and you should see your “TOTAL TIME” begin to increase.

EXAMPLE: If you found that it took 10 minutes to pump the well dry of product and 2 hours for the product to return to static level after the skimmer was turned off. You would then set up 12 intervals at 2 hours apart start times, with run times of 10 minutes.

Computer Data Windows For The SET UP & DIRECT Modes

Turn on the power to the computer controller. You should see the “PROGRAM OR RUN” window. Press the MENU KEY to begin going through the different windows.

PROGRAM MODE:

1. Mode Selection Window
PROGRAM OR RUN
Choose “PROGRAM” and press the MENU key
2. Set Current Clock Time Window
SET TIME: **HH:MM**
USE 24 HOUR TIME
Press the MENU key
3. Set Start Time and Run Time Window
START AT: **HH:MM** USE 24 HOUR TIME
RUN FOR: **HH:MM** Hours:Minutes
Change Interval # to add another start time.
Press the MENU key
4. Choose Interval Frequency Window
RUN PROGRAM
EVERY CHOOSE UP TO 30 DAYS DELAY
Press the MENU key
5. Choose “RUN”

Press the MENU key

Key Pad Descriptions

MENU: This Key changes windows.

The left & right Keys move the cursor to the next programmable field.

▲: This Key increases the value in the field the cursor is on.

▼: This Key decreases the value in the field the cursor is on.

TIME RESET: This Key will reset the elapsed run time of a station when you are in the STATUS WINDOW.

REV: This Key is to show you what software version is currently being used by your computer.

DEL: This Key will replace all programmed values with preset default values. This Key will NOT delete the elapsed run time in the STATUS WINDOW.

Solar Panel Installation

STEP 1. Attach solar panel to the solar panel bracket and then to pole above the controller.

STEP 2. Disconnect controller power cord from battery.

STEP 3. Remove the lower junction box plate from the controller. Take the solar panel cable and insert through opening in bottom of the controller junction box. Attach red wires from the solar panel cable, battery cable, and the controller together. Attach black wires from the solar panel cable, battery cable, and the controller together.

STEP 4. Attach the red power cable battery clip to the positive terminal on the battery and the black power cable battery clip to the negative terminal on the battery.

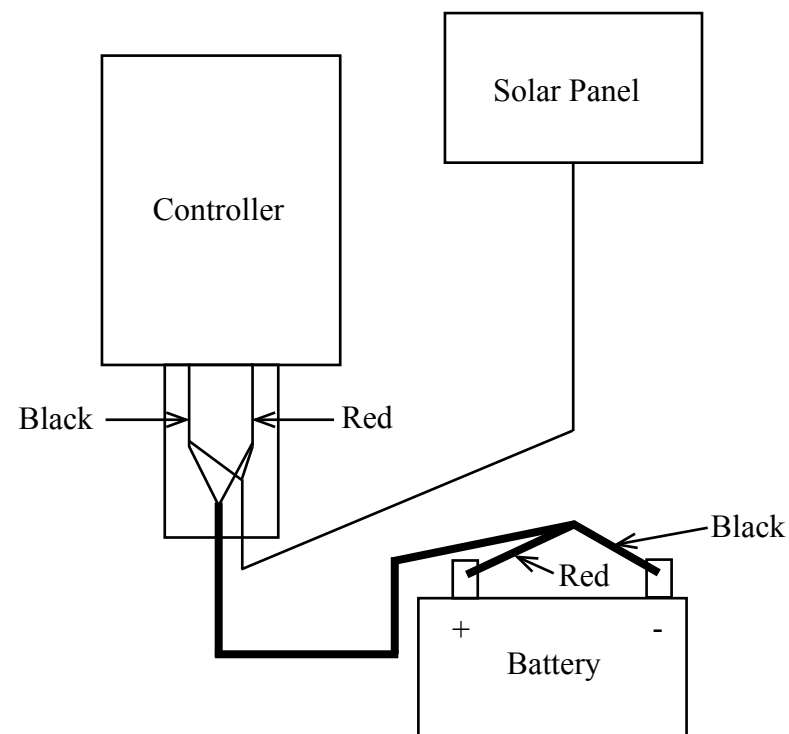

Replacing The Skimmer Filter

1. Remove the stop bolt at the bottom of the well screen housing.
2. Remove the skimming assembly from the well screen housing.
3. Remove the skimming filter from the float assembly. No tools required.
4. Push on a new skimming filter onto the float assembly and return skimming assembly to the well screen housing.
5. Secure the stop bolt to the well screen housing.

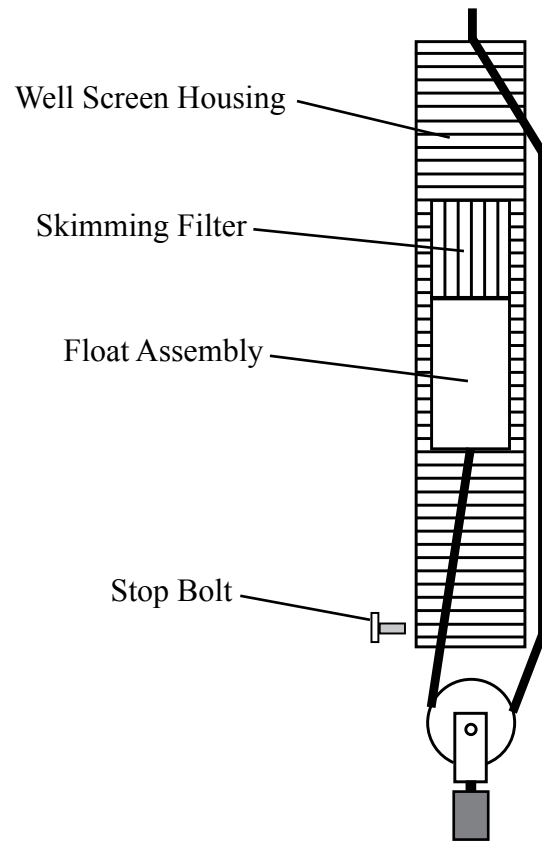

3000ES Controller Mounting

