

ADJ200 Smart Skimmer and 2510ES Electronic Control Station Single Skimmer Operations Manual

Caution:

**Read rules for safe operation and instructions
carefully.**

© Copyright 2001 REV 07/2010

XITECH
Instruments, Inc.

**06 Camino De Los Desmontes, Placitas, New Mexico 87043
Phone: 505-867-0008 Fax: 505-867-0212
Web site: www.xitechinc.com
E-mail: xitechinc@xitechinc.com**

3 YEAR WARRANTY

This product is warranted to the original purchaser to be free from defective materials and workmanship. Under this warranty the product will be repaired or replaced at our option, without charge for parts or labor.

This warranty does not apply to the skimmer hydrophobic filter or air logic valve.

The period of this warranty covers 3 years on parts and labor from date of original purchase.

This warranty entitles the original purchaser to have the warranted parts and labor rendered at no cost for the period of the warranty described above when the instrument is carried or shipped, pre-paid, to our factory, together with proof of purchase.

RULES FOR SAFE OPERATION

- 1. Please review carefully and abide by the maximum limits placed on each type of equipment.**
- 2. Please follow standard electrical practices and safety precautions when installing AC power to our products.**
- 3. Do not operate this equipment in a CLASS 1 explosive area.**

Product Recovery System Installation

The system (Figure 1) relates to floating hydrocarbon recovery in wells two inches in diameter and larger. This system includes: an intrinsically safe ADJ200 pneumatic Smart Skimmer (Figure 2) which removes only the product to a sheen down to 200 feet deep; and a electronic Control Station Model 2510ES which operates the skimmer intermittently, records run time, and has a high level tank shutoff.

STEP 1. Place electronic Control Station Model 2510ES (Figure 1) near the air source, power source, and holding tank if possible. **CAUTION:** The standard electronic controller is NOT intrinsically safe. If this controller must operate in a CLASS I area, the XITECH Model 2550ES CLASS I controller will be required.

STEP 2. Install holding tank shutoff assembly into holding tank (a 2" standard pipe inlet will be required in the holding tank). The level of product in the holding tank can be set by raising or lowering the liquid level float switch rod. Plug the high level shutoff switch cable connector into the left end of the controller (Figure 1).

STEP 3. Attach power line from the AC power source to the right end of the control station (Figure 1). Turn on the controller power switch. If the red "Product Tank Full" light stays on, you have a problem with tank shutoff wiring. Turn off the power switch and re-check the tank shutoff wiring. If the light continues to stay on, call the factory.

STEP 4. The control station has a light bulb fixture at the right end of the control station that is used for automatically heating the box during freezing conditions. Install a 60 watt light bulb into the light socket just inside the right end of the control station. This light bulb is automatically controlled by an internal thermostat that turns on the light when the control station temperature goes to 32 degrees F. The control station also has ventilation fans that are thermostatically controlled. The fans turn on when the control station temperature reaches 100 degrees F.

ADJ200 Smart Skimmer and 2510ES Electronic Control Station with Tank Shutoff

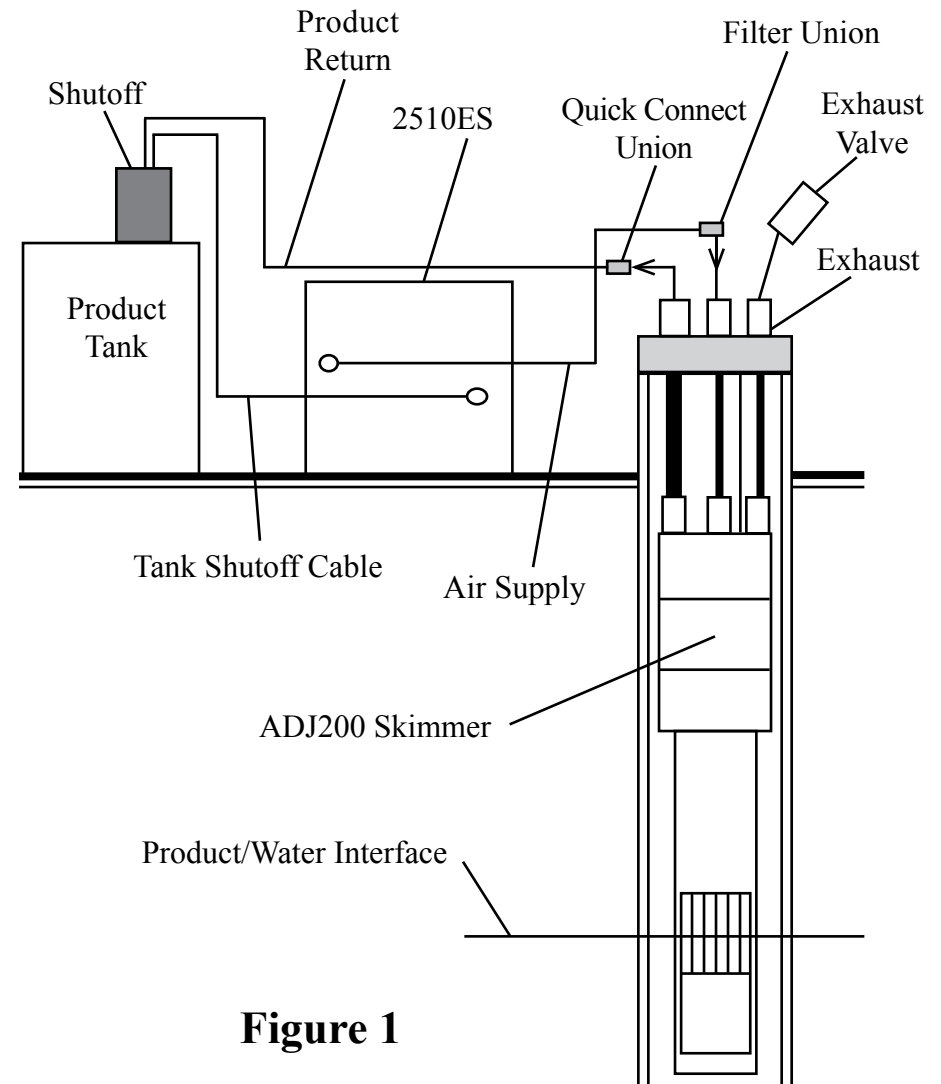

Figure 1

STEP 5. Install horizontal air supply line to the well. Use 3/8" OD tubing for the horizontal run. **CAUTION:** Please keep dirt from getting into these lines! Attach a filter union onto the end of this line at the well vault.

STEP 6. Install horizontal product return line to the well. Use 1/2" OD tubing for the horizontal run. Attach a quick connect union onto the end of this line at the well vault.

STEP 7. Position the skimmer and well cap on the ground near the well. Cut a length of 1/4" OD air supply tubing to cover the distance from the top of the well down to water/product interface, plus 5 feet. **NOTE:** If the skimmer is over 70 feet deep, use 3/8" OD air supply tubing in stead of 1/4" OD tubing. Slide enough tubing through the well cap and attach the end of the tubing to the top of the skimmer tube fitting labeled "G" (Figure 2). If the product thickness is greater than 1 foot, position the skimmer's "Black Reference Line" on skimmer well screen 1 foot below top of product. If the product thickness is less than 1 foot, position the skimmer's "Black Reference Line" on skimmer well screen at the water/product interface.

STEP 8. Cut a length of 5/16" OD product tubing same length as the air supply line. Install 5/16" OD product tubing through the well cap tube fitting labeled "P" (Figure 2). Slide enough tubing through the well cap and attach the end of the tubing to the top of the skimmer tube fitting labeled "P". **CAUTION:** Do not kink the tubing.

STEP 9. Cut another length of 1/4" OD air exhaust tubing same length as air supply line. Install 1/4" OD air exhaust tubing through the well cap tube fitting labeled "E". Slide enough tubing through the well cap and attach the end of the tubing to the top of the skimmer tube fitting labeled "E".

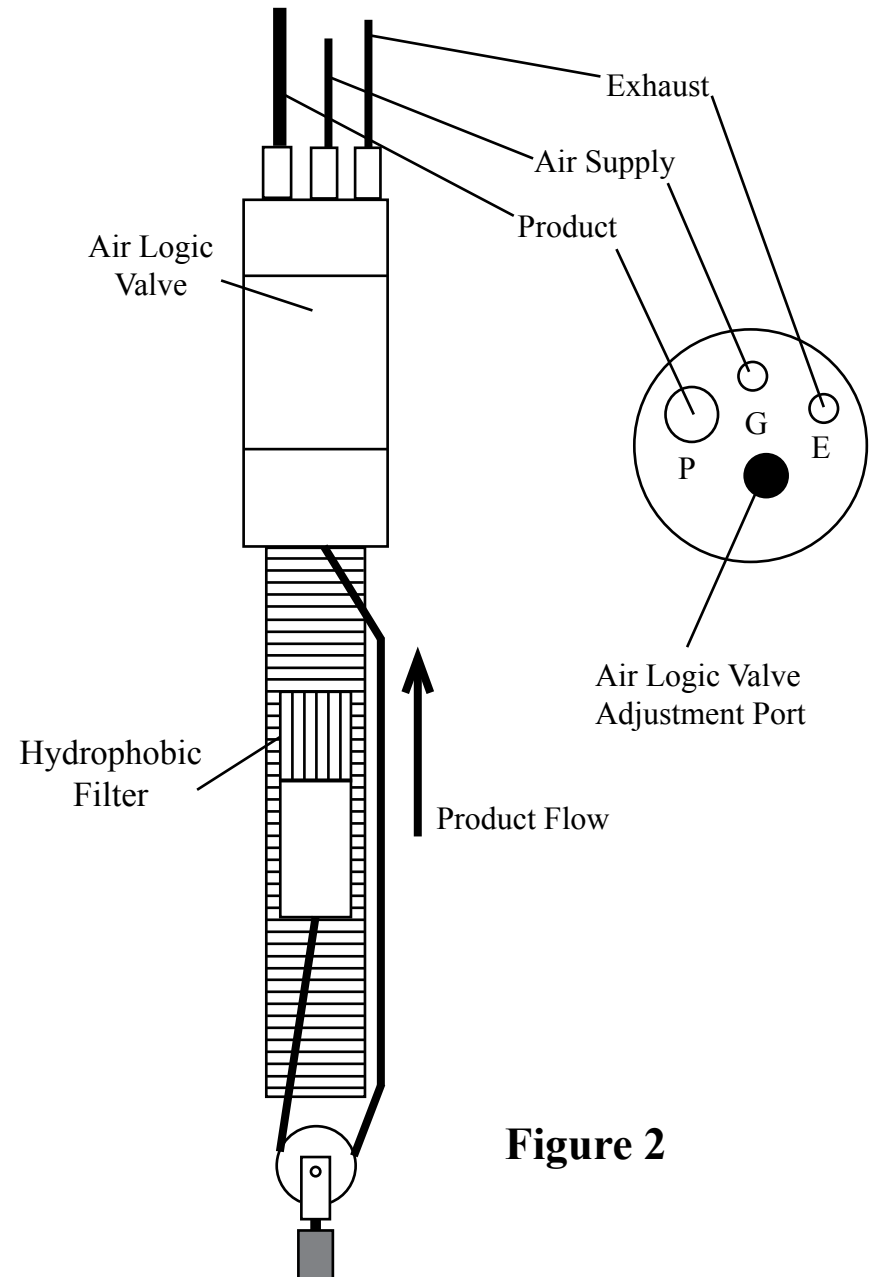

Figure 2

STEP 10. Cut a length of safety rope same length as air supply line. Attach the safety rope from inside the well cap to the top of the skimmer head. The tubing will carry the weight of the skimmer.

STEP 11. Attach the 3/8"-1/4" filter union onto the 1/4" air supply line coming out of the well cap.

STEP 12. Attach the 5/16" product line coming from the well cap into the inlet of the quick connect union.

STEP 13. Attach the exhaust check valve onto the end of the 1/4" air exhaust line coming out of the well cap.

STEP 14. Go to the controller and turn the Pumping Time knob to the CONT. position, turn on the power switch at the controller to start the skimmer running. The Digital Readout should have a blinking "-" which indicates that the totalizing timer is running. Observe that the skimmer is making a pumping noise. The exhaust check valve should have an intermittent pulsing sound about once every second. NOTE: There is a 4 second delay from the time the compressor starts to the time air will flow out of the box. This causes the pressure gauge to read high pressure for a moment.

STEP 15. While the skimmer is running at the desired operating air pressure above ground, confirm or adjust skimmer pulse rate. To adjust skimmer pulse rate, remove small plug at the top of the skimmer pump head and insert a small flat-head screwdriver into the air logic valve located inside the pump head. Turn clockwise to decrease pulse rate. NOTE: Factory sets skimmer pulse rate to 60 pulses per minute. Maximum recommended pulse rate is 100 pulses per minute. Lower pulse rates will consume less air.

STEP 16. You are now ready to install skimmer in the well. CAUTION: Please remove skimmer float shipping tie wraps before placing skimmer in well.

2500ES Electronic Controller

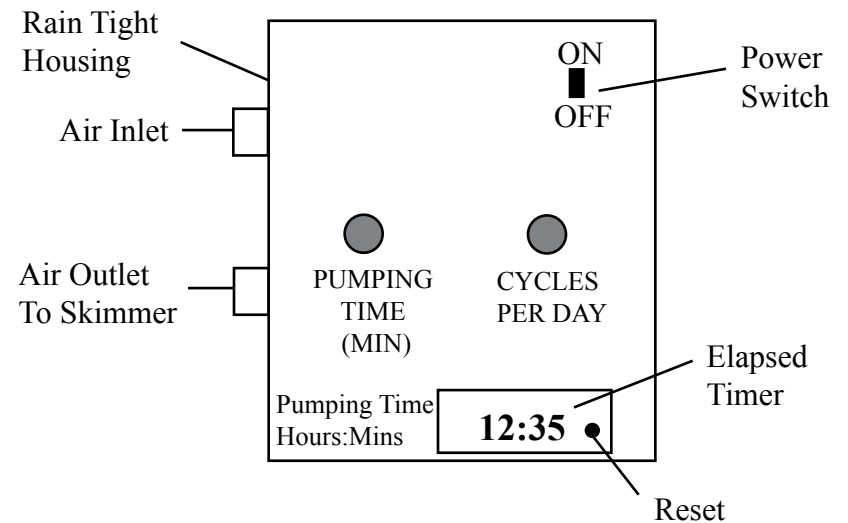

Figure 3

Operation of the Product Recovery System

Reset the digital timer on the controller to 0-00.

Turn on the power to the controller and wait for product to come to the surface. If your skimmer is less than 30 feet deep, product should show up above ground in about 2 minutes.

Observe the product being discharged by the skimmer. Be sure no water is being pumped. If water does appear, pull the skimmer out of the well and check to see if the shipping tie wraps have been removed from the skimmer well screen area. If there are no tie wraps, give Xitech a call toll free at 888-867-9483.

Record the amount of time it takes to empty the well of product. When the well is empty of product, turn off the controller power.

If you found it took 10 minutes to pump the product off, set the “pumping time” to 5 minutes (Xitech’s 1/2 Rule).

You now have to guess how many times a day to empty the well. A good guess would be once a day for slow recovering product and 3-6 times a day for fast recovering product.

NOTE: Timing begins when power is applied. The settings ending with “D” means days delay. For example: If the “cycles per day” is set to 5D and you turn on the power to the controller, the controller will immediately operate the skimmer for the selected amount of pumping time and then wait 5 days before running the skimmer again.

YOU ARE NOW READY TO OPERATE THE SYSTEM! TURN ON THE POWER TO THE CONTROLLER.

PLEASE CALL XITECH FROM THE FIELD IF YOU HAVE ANY TROUBLE WITH YOUR INSTALLATION.

FINAL NOTE: Keep in mind that you are trying to empty the formation of free product over a long period of time. To do this, you must always try to keep some free product thickness in your recovery well at all time while removing free product daily.

Replacing The Skimmer Filter

1. Remove the stop bolt at the bottom of the well screen housing.
2. Remove the skimming assembly from the well screen housing.
3. Remove the skimming filter from the float assembly. No tools required.
4. Push on a new skimming filter onto the float assembly and return skimming assembly to the well screen housing.
5. Secure the stop bolt to the well screen housing.

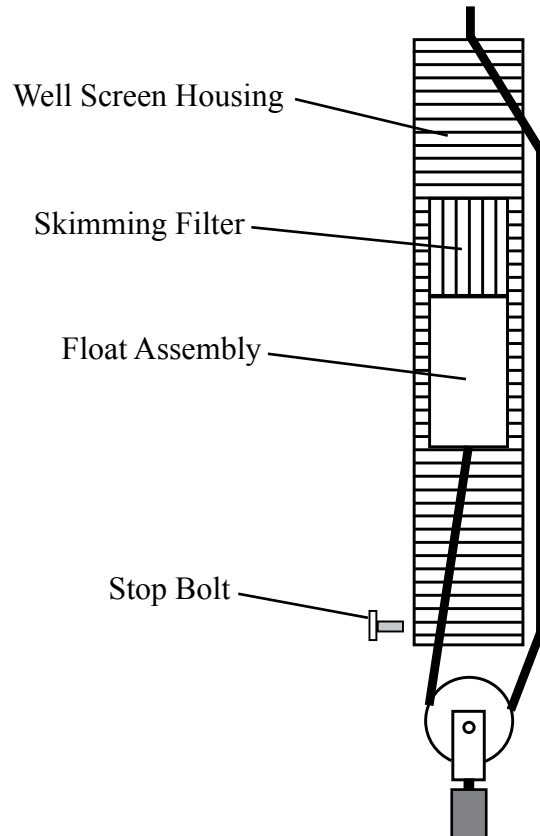

Notes