

ADJ1100 Smart Pump and 2500ES Electronic Controller Single Pump Operations Manual

Caution:

**Read rules for safe operation and instructions
carefully.**

© Copyright 1999 REV 07/2010

XITECH
Instruments, Inc.

06 Camino De Los Desmontes, Placitas, New Mexico 87043

Phone: 505-867-0008 Fax: 505-867-0212

Web site: www.xitechinc.com

E-mail: xitechinc@xitechinc.com

3 YEAR WARRANTY

This product is warranted to the original purchaser to be free from defective materials and workmanship. Under this warranty the product will be repaired or replaced at our option, without charge for parts or labor.

This warranty does not apply to the air logic valve or diaphragm.

The period of this warranty covers 3 years on parts and labor from date of original purchase.

This warranty entitles the original purchaser to have the warranted parts and labor rendered at no cost for the period of the warranty described above when the instrument is carried or shipped, pre-paid, to our factory, together with proof of purchase.

RULES FOR SAFE OPERATION

- 1. Please review carefully and abide by the maximum limits placed on each type of equipment.**
- 2. Please follow standard electrical practices and safety precautions when installing AC or DC power to our products.**

DNAPL Recovery System Installation

The system (Figure 1) relates to sinking DNAPL recovery in wells four inches in diameter and larger. This system includes: an intrinsically safe pneumatic ADJ1100 Smart Pump (Figure 2) which removes the DNAPL down to 200 feet deep; and a three function electronic Controller Model 2500ES that operates the pump intermittently, records run time, and has a high level tank shutoff assembly.

STEP 1. Mount electronic Controller Model 2500ES (Figure 3) in a vertical position near the air source, power source, and holding tank if possible. **CAUTION:** The standard electronic controller is NOT intrinsically safe. If this controller must operate in a CLASS I area, the XITECH Model 2550ES CLASS I controller will be required. Air supply needs to be free of WATER and OIL to have minimum maintenance. **NOTE:** The ON/OFF switch inside the controller is for AC and DC power.

STEP 2. Install holding tank shutoff assembly into holding tank (a 2" standard pipe inlet will be required in the holding tank). The level of product in the holding tank can be set by raising or lowering the liquid level float switch rod. Wire the shutoff switch cable into the controller (Figure 3). **NOTE:** If additional signal cable is needed to position the holding tank assembly further away from the controller, use 18 gauge 2-conductor wire.

STEP 3. Attach power line from the AC or DC power source to the controller (Figure 3). Turn on the controller power switch. If the red "Product Tank Full" light stays on, you have a problem with tank shutoff wiring. Turn off the power switch and re-check the tank shutoff wiring. If the light continues to stay on, call the factory.

If you plan to operate this controller for a long period of time on a DC power source, we suggest you use a solar panel (see page 8 for installation) to maintain power in the battery.

ADJ1100 Smart Pump and 2500ES Electronic Controller with Tank Shutoff

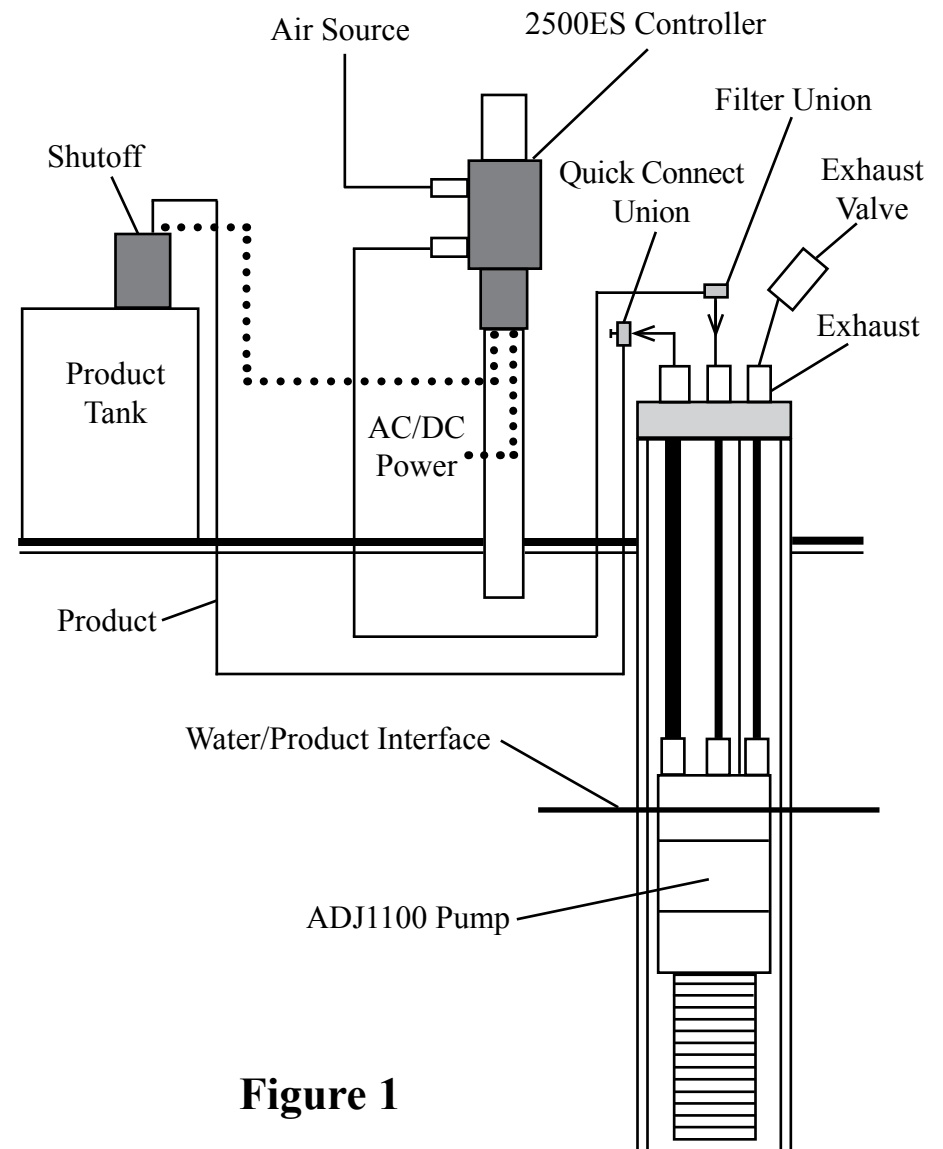

Figure 1

STEP 4. Install 3/8" OD air supply tubing from the main air source to the INLET of the Controller. Do NOT apply air pressure YET.

STEP 5. Install horizontal air supply line to the well. Use 3/8" OD tubing for the horizontal run. **CAUTION:** Please keep dirt from getting into these lines! Attach a filter union onto the end of this line at the well vault.

STEP 6. Install horizontal product return line to the well. Use 1/2" OD tubing for the horizontal run. Attach a quick connect union onto the end of this line at the well vault.

STEP 7. Position the pump and well cap on the ground near the well. Cut a length of 3/8" OD air supply tubing to cover the distance from top of the well down to the bottom of the well, plus 5 feet. Slide enough tubing through the well cap to position the pump at the bottom of the well and attach the end of the tubing to the top of the pump tube fitting labeled "G" (Figure 2).

STEP 8. Cut a length of 1/2" OD product tubing same length as the air supply line. Install 1/2" OD product tubing through the well cap tube fitting labeled "P" (Figure 2). Slide enough tubing through the well cap and attach the end of the tubing to the top of the pump tube fitting labeled "P". **CAUTION:** Do not kink the tubing.

STEP 9. Cut another length of 3/8" OD air exhaust tubing same length as air supply line. Install 3/8" OD air exhaust tubing through the well cap tube fitting labeled "E". Slide enough tubing through the well cap and attach the end of the tubing to the top of the pump tube fitting labeled "E".

STEP 10. Cut a length of safety rope same length as air supply line. Attach the safety rope from inside the well cap to the top of the pump head. The tubing will carry the weight of the pump.

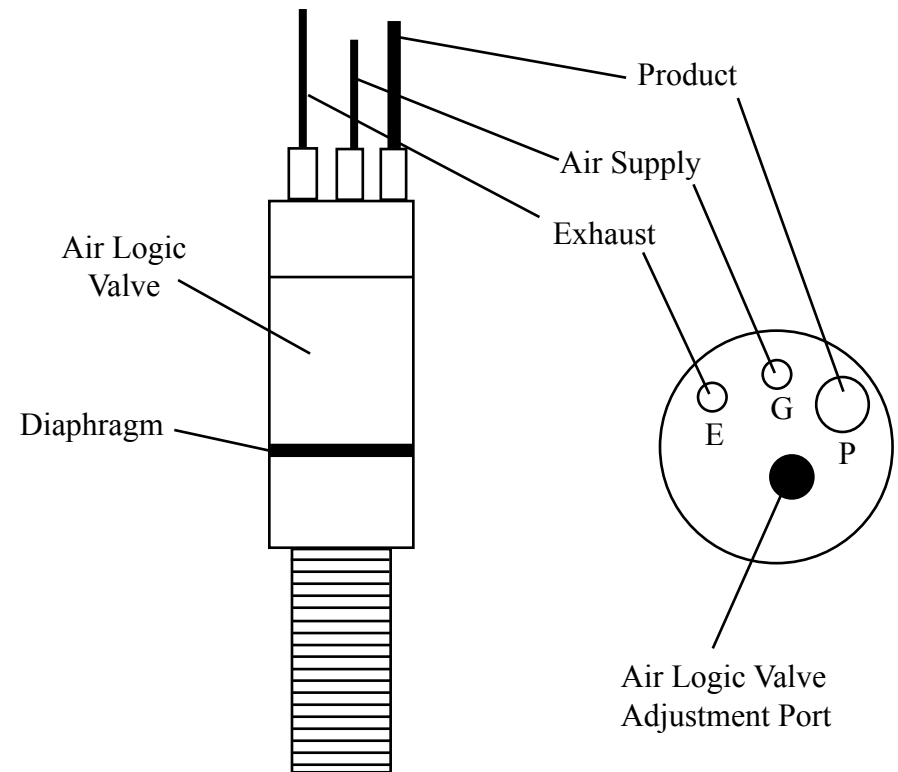

Figure 2

2500ES Electronic Controller

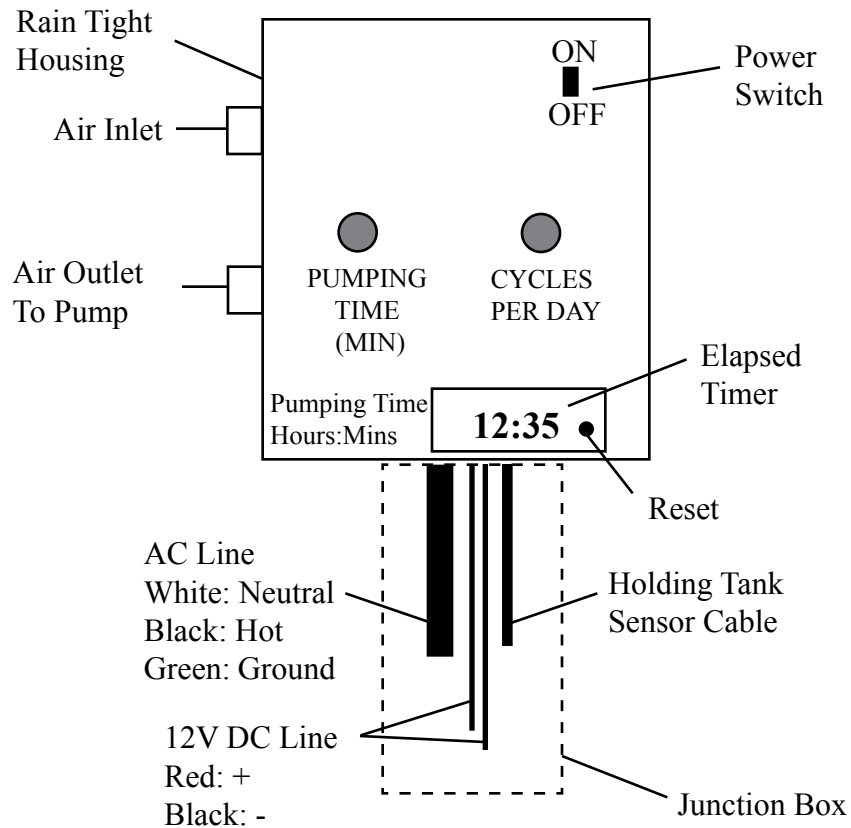

Figure 3

STEP 11. Attach the 3/8" filter union onto the 3/8" air supply line coming out of the well cap.

STEP 12. Attach the 1/2" product line coming from the well cap into the inlet of the quick connect union.

STEP 13. Attach the exhaust check valve onto the end of the 3/8" air exhaust line coming out of the well cap.

STEP 14. Set operating air supply pressure.

$$\text{AIR PRESSURE} = 35 + \frac{\text{Total Vertical Lift}}{2.85}$$

Minimum operating pressure is 35 PSI
Maximum operating pressure is 125 PSI

STEP 15. Go to the controller and turn the Pumping Time knob to the CONT. position, turn on the power switch at the controller to start the pump running. The Digital Readout should have a blinking "-" which indicates that the totalizing timer is running. Observe that the pump is making a pumping noise. The exhaust check valve should have an intermittent pulsing sound.

STEP 16. While the pump is running at the desired operating air pressure above ground, confirm or adjust pump pulse rate. To adjust pump pulse rate, remove small plug at the top of the pump head and insert a small flat-head screwdriver into the air logic valve located inside the pump head. Turn clockwise to decrease pulse rate. **NOTE:** Factory sets pump pulse rate to 60 pulses per minute at 50 psi operating pressure for low viscous fluids and 30 pulses per minute for high viscous fluids. Maximum recommended pulse rate is 80 pulses per minute. Lower pulse rates will consume less air.

STEP 17. You are now ready to install pump in the well.

Operation of the Product Recovery System

Reset the digital timer on the controller to 0-00.

Turn on the power to the controller and wait for product to come to the surface. If your pump is less than 30 feet deep, product should show up above ground in about 2 minutes.

Record the amount of time it takes to empty the well of product. When the well is empty of product, turn off the controller power.

If you found it took 10 minutes to pump the product off, set the “pumping time” to 5 minutes (Xitech’s 1/2 Rule).

You now have to guess how many times a day to empty the well. A good guess would be once a day for slow recovering product and 3-6 times a day for fast recovering product.

NOTE: Timing begins when power is applied. The settings ending with “D” means days delay. For example: If the “cycles per day” is set to 5D and you turn on the power to the controller, the controller will immediately operate the pump for the selected amount of pumping time and then wait 5 days before running the pump again.

YOU ARE NOW READY TO OPERATE THE SYSTEM! TURN ON THE POWER TO THE CONTROLLER.

PLEASE CALL XITECH FROM THE FIELD IF YOU HAVE ANY TROUBLE WITH YOUR INSTALLATION.

FINAL NOTE: Keep in mind that you are trying to empty the formation of free product over a long period of time. To do this, you must always try to keep some free product thickness in your recovery well at all time while removing free product daily.

Solar Panel Installation

STEP 1. Attach solar panel to the solar panel bracket and then to pole above the controller.

STEP 2. Disconnect controller power cord from battery.

STEP 3. Remove the lower junction box plate from the controller. Take the solar panel cable and insert through opening in bottom of the controller junction box. Attach red wires from the solar panel cable, battery cable, and the controller together. Attach black wires from the solar panel cable, battery cable, and the controller together.

STEP 4. Attach the red power cable battery clip to the positive terminal on the battery and the black power cable battery clip to the negative terminal on the battery.

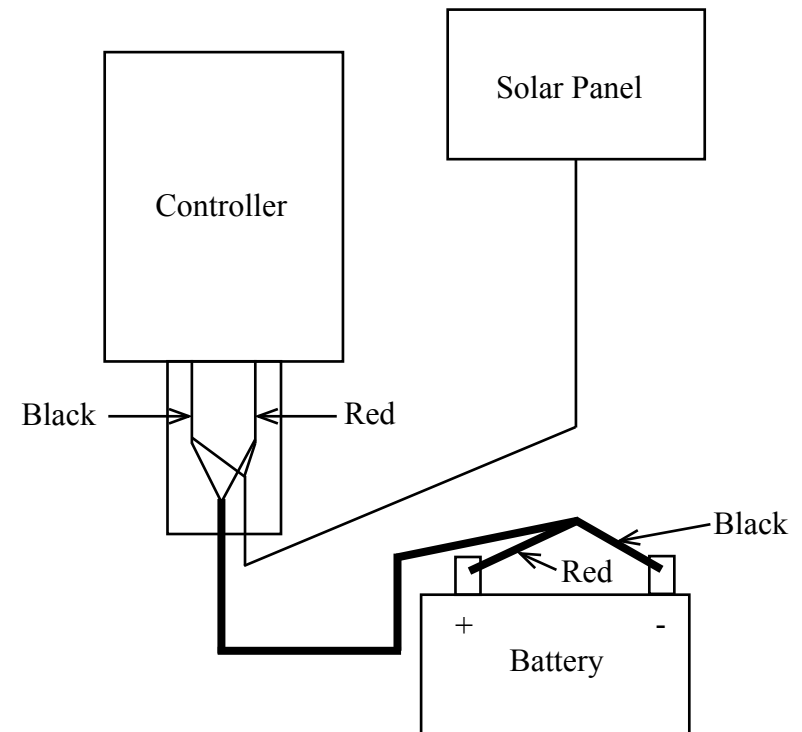

2500ES Controller Fuse Information

Two versions of the 2500 PC Board is currently available.

The older version has two glass fuses on the back side of the PC Board. The AC power glass fuse is next to the transformer and is a 1 amp “Slow-blow” fuse. The other fuse at the edge of the PC Board is for DC power and is a 2 amp “Slowblow” fuse.

The newer version PC Board has only one glass fuse that is next to the transformer. This fuse is for AC power and is a 1 amp “Slowblow” fuse. The DC power fuse is an automatic resettable fuse that does not need changing.

Replacing The Pump Diaphragm

1. Loosen all bolts until bottom can be detached. Do not separate pump head, valve housing or diaphragm from the six bolts at this time.
2. Lay pump on its side on the table and remove the diaphragm from all six bolts.
3. Place new diaphragm onto the six bolts and reattach upper pump parts with the pump bottom.

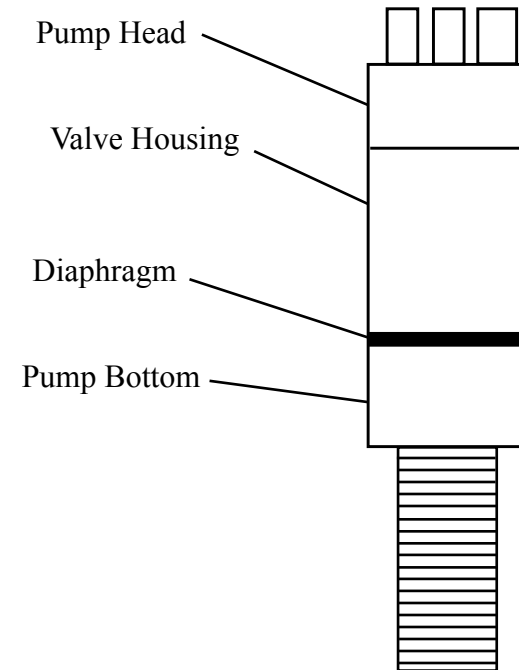

2500ES Controller Mounting

Notes

